



10/12  
10/14/13/6





# THE WORSHIP OF SATAN IN MODERN FRANCE

BEING A SECOND EDITION OF

MODERN MYSTICS AND MODERN MAGIC

CONTAINING ALSO

Sketches of Swedenborg, Boehme, Madame Guyon, Stainton Moses,  
the Illuminati, the Kabbalists, Theosophists, Spiritists,  
the Society of Psychical Research, etc.

BY

ARTHUR LILLIE

*Author of "The Influence of Buddhism on Primitive Christianity," "Madame  
Blavatsky and her 'Theosophy,'" etc*



London

SWAN SONNENSCHN & CO LIM<sup>D</sup>  
PATERNOSTER SQUARE, E.C

1896

SWAN SONNENSCHN & CO  
LIM<sup>D</sup>  
PATERNOSTER SQUARE, E.C.  
NOT EXCHANGEABLE AND  
NOT SALABLE

BUTLER & TANNER,  
THE SELWOOD PRINTING WORKS,  
FROME, AND LONDON.

G. 23<sup>E1</sup> AP<sup>15</sup>

STATE CENTRAL LIBRARY, W.L.A.

55-A B 7 Road,

Calcutta-700 090

25.4.85

## PREFACE TO SECOND EDITION

SINCE this little work was first issued to the public such strange revelations have come from France that it is felt that a work on "Modern Magic" without a fairly full notice of these would be most incomplete. Reliable witnesses have come forward who assert that the black mass is celebrated in at least four places of worship in Paris alone, and in these "temples" Satan is worshipped as a purely evil spirit.

What is the black mass? I will give at once a description of it from the pages of M. Huysmans. This gentleman, according to the *Revue des Deux Mondes*, is the leading expositor of the cultus. Disgusted with modern materialism he plunged into the fine mysticism of St. John of the Cross, Gorris, Fenelon. He went for experiment for some time into a monastery of Trappists. He examined everything *Spiritisme, Satanisme*. Two novels, partly biographical, were the result. In one of these the hero, Durtal, is taken by a fashionable lady, Madame de Chantelouve, to a black mass performed by a renegade priest, Canon Docre. I condense the narrative and soften it considerably. With black masses Dr. Bowdler is quite a necessary institution.

With Madame de Chantelouve Durtal entered a chapel with a low ceiling supported by tarred beams. Its windows were hidden with great curtains, its walls were discoloured and fissured. Durtal staggered. A gas stove hummed, an abominable smell of blue mould, damp, new stoves, alkalis, and smouldering aromatic herbs and resins half suffocated him. Carefully he felt his way in the darkness, which two sanctuary lamps scarcely relieved, though hung in suspenders of gilt bronze and pink glass.

In a corner certain worshippers, chiefly women, were to be detected, solemn and silent. Their faces were hidden.

'An unhealthy looking child dressed in scarlet began to light the candles at the altar. This was the ordinary altar of French churches, with a tabernacle surmounted with a crucifix which had been subjected to shocking indignities. The candles were black, and a smell of pitch joined itself to the other pestilences of the apartment.

"It is a real chapel?" Durtal said to the lady.

"Yes, these are the remains of an old convent of the Ursulines which for some time was used for storing hay. That stout lady there bought it up. Those ladies and gentlemen hiding a little in the shade are *Sataniques*."

"I feel quite suffocated. From what part of earth, heaven, or hell, come the fearful stench of those brasiers?"

"Henbane and datura, myrrh and nightshade! These are the perfumes that delight Satan, our Master."

The lady said these last words with a changed voice and a strange solemnity. Her eyes quivered and she was very pale.

Suddenly all the worshippers ran forward and knelt down on the chairs. Canon Docre had come in.

Preceded by the unhealthy choir boy who had been joined by an unhealthy companion, the priest advanced to the altar. He was strongly but clumsily built, and wore a red cap adorned with two bison horns in red stuff. His chasuble was of the form of ordinary chasubles, but of the colour of dried blood. Conspicuous in front of it, in a triangle adorned with an arabesque of colchicum, savin, euphorbia and long leaved sorrel, a he-goat standing upright presented his horns.

"It's an ordinary low mass," whispered Durtal to the lady. The priest was going through the prescribed genuflexions and bows of the Catholic ritual, and the two unhealthy children on their knees were responding to his Latin chant with screaming voices.

Madame de Chantelouve gave a sign of negation; and soon a variation occurred. The children went out and brought in a number of incense burners and brasiers, and the congregation eagerly seized these and allowed the



mephitic fumes to invade their nostrils and their lungs. Soon dresses were unhooked, and groans and faintings were abundant.

The priest now descended the stairs of the altar still facing the burlesque crucifix. He knelt down on the last step, and pronounced an address in metallic tones.

“Master of scandals! Dispenser of the benefits and booty of crime! Administrator of sumptuous sins and great vices! Satan, it is thee whom we adore, logical God, just God!

“Legate of false agonies thou driest our lying tears, thou savest the honour of families by hiding our shame and our secret sins. To poverty in its exasperation, and defeat in its humiliation, thou bringest hypocrisy, ingratitude, pride, to defend us from the attacks of the children of God—the rich.

“Suzerain of hate, accountant-general of scorns and injustices, thou givest to the injured man vengeance, murders, the ineffable joy of completed reprisals. Thy name is Pleasure! Thy home is Nature! Thou delightest not in the sterile lives of priests and nuns and their death-like torpor. Thou lovest lust! Thou listenest to carnal prayers.

“Master, thy faithful servants on their knees implore thee to vouchsafe to them the ecstasies that result from forbidden deeds, they pray thee to help them in casting those malefic spells which rout man's reason. They pray thee to forgive them if they desire the torture of their neighbours. In a word, they ask of thee glory, riches, power. They and thou are of the disinherited of the universe.”

The Canon then assailed the figure on the cross, and poured out a flow of blasphemy that I need not write down. He finished by blessing the congregation with his left hand. Then came the ignoble and filthy termination of the rites. The congregation, as mad as the possessed zealots of an American revival meeting, scrambled for the sacramental wafer after the Canon had indecently outraged it.

Is all this the turbid dream of a romance writer of extra French theatrical proclivities? Are these worship-

pers a few crazy enthusiasts masquerading, as it were, in the devil-clothes of a carnival masked ball? Not at all, says M. Huysmans: the worship of Satan is the worship of wealth, distinction, power. The Church affects to despise these things, and promises in their stead "a beatific immortality which no serious thinkers now believe in.

"The principle of evil and the principle of good, the God of the light and the God of the darkness, two rivals, dispute for our souls. In the present nineteenth century it is evident that the good Deity is down, and the bad one has the world all to himself." Thus a *Sataniste* argues in the work. These zealots are far from being few and unimportant:—

"Confessors of convents, prelates, abbesses, are amongst them, and in Rome, the centre of modern magic, high dignitaries. The lay element is recruited from rich classes. That explains how scandals are smothered away."

"The crucial point," says M. Huysmans, "is to consecrate the host and destine it to infamous usages. Everything is in that. The rest varies, there is no regular ritual for the black mass." The French author gives receipts for this from Psellus, *De operatione Dæmonum*, and other grim sources. Two conflicting ideas seem to dominate these.

1. The *Satanistes* of the first group seem to be real Christians; that is, believers in the Incarnation and in Transubstantiation. In consequence they consider it of vital importance to have a fully ordained priest for the rites, and real wafers stolen from the churches. The dominant idea seems to be that the most delicate flattery to Satan is to let him witness real insults to a Christ really present.

2. The second group make up their wafers of babies' blood and every conceivable filth. This seems a grim burlesque of the Christian's main rite by sceptics, for they can scarcely hold that it would please Satan to transubstantiate himself in ordure.

The head of what is called Occult Masonry, in France, as distinguished from the "Atheistic Freemasons of the

Grand Orient," has published a pamphlet in which he announces that this black mass is non-existent. To this pamphlet of M. Papus I shall return. Here I shall merely quote an interesting article from the *Daily Chronicle*, December 20th, 1895.

"The subject of devil-worship in France is one which in England will provoke a shudder or a smile. The fact, however, that there are now four conventicles in Paris in which the creed and liturgy of the Evil One are set forth cannot fail to interest a curious observer. Two able writers, M. Jules Bois and M. Huysmans, have quite recently unearthed the records of the dreadful Abbé Guibourg's 'black' mass, in which Madame de Montespan was the blasphemous devotee. Dr. G. Legué, in a volume entitled, *Médecins et Empoisonneurs au XVII<sup>e</sup> Siècle*, records beyond all cavil that the 'Tout Paris' of a couple of hundred years ago flocked clandestinely to the hideous chapel in the Rue de Beauregard, in which uncleanness and infanticide were raised to the dignity of a new religion. The interest of to-day, however, lies in that end-of-the-century Satanism, which baffles all comprehension. M. Jules Bois, with whom I have repeatedly conversed on the subject, makes a point of emphasising the distinction between the Satanists and Luciferians. The latter take the Spirit of Evil as a rebel deity, and are the adherents of his supposed insurrection against a supreme being. They have, it appears, always existed in Paris.

"The real devil-worshippers are, however, the most topical French sect of these latter days. Their puzzling profanity is now a matter of grave study. Their temples are in the Rue Jacob, the Rue Rochechouart, and within a few yards of the Panthéon. Only the initiated are admitted. The Bishops of Grenoble, Versailles, and Orleans have thought it necessary to issue pastorals, ordering their clergy to guard the tabernacles in their churches from profanation. Not long ago a service of 'Reparation' was performed at Notre Dame, because the consecrated hosts were stolen from a side chapel. The silver-gilt ciborium in which they were placed was left behind, so that it was made clear that the act was not

that of a vulgar thief. These hosts are obtained by the feminine Satanists, who take them to the conventicles of the sect, where they are treated in sacrilegious fashion. Those who have witnessed these fiendish functions mention certain phrases which even in books on the subject are narrated in Latin footnotes. The most noteworthy feature of the downright Satanism of to-day is that it necessarily symbolises an acceptance of revealed dogma and of a personal devil. The followers actually profess that the being whom they describe as the vanquished foe of the Archangels Michael and Raphael actually manifests himself to them on certain occasions. Sheer lunacy appears at first to be the only adequate explanation of this extraordinary flock. So far no priest has joined their ranks, and this fact probably accounts for the stealing of consecrated wafers. A Satanist hymn-book has been privately printed, and I may add that surpliced boy choristers assist at the services. The calendar is a blasphemous reversal of the old Christian dates. The great feast of the year is Good Friday. It is probable that the doings of the Satanists will soon be known to the general public. But I question whether the Parisians will ever take kindly to this unspeakable sect."

The evidence for the Luciferists stands on a different basis from the evidence of Satanism. Many initiates and other writers have come forward with works that are mostly bulky. We have Dr. Bataille (Hacke), M. Jules Bois, M. de la Rive. But the writer that has created the greatest sensation in Catholic circles is a Miss Diana Vaughan, *Grand Mistress* of New York, and President of the Triangle, Phébé La Rose. She has since joined the Catholic Church, and has written her confessions, entitled *Memoires d'une Ex Palladiste*, and is on many points an important witness. c

In Charleston, after the war, was a General Albert Pike. This gentleman was born in 1809. He served through the campaign on the Confederate side. General Pike was a Freemason and Rosicrucian, Grand Commander of the Supreme Council of Charleston. America in those days had gone quite mad on spirit-rapping. Albert Pike was a medium, and he conceived the happy idea of fusing the

rappers and the masons, and of animating the dry bones in the valley. He formed an inner lodge of Palladists—a name was necessary. And a more important step was taken, ladies were admitted to this inner lodge. By good luck two of these turned out to be very strong mediums, Miss Sophia Walder and Miss Diana Vaughan. The success of the Palladists has been amazing. They quickly overran America, and crossing the water, invaded France, Italy, Constantinople, India. On the death of Albert Pike, June 20th, 1881, one Lemmi, an Italian, usurped his post, and the headquarters of the Palladists are now at Rome.

Palladism on the surface seems a burlesque of the Roman Catholic Church. Romanism may be called a dualism with the Lord of the Bible (Adonai) for the good spirit, and Lucifer with hoofs, horns, and a tail for the evil spirit. Palladism reverses this. Adonai, who is not so much Christ as the Romish Church personified, is the evil spirit; and Lucifer, the light-bringer, is the *Dieu bon*, retaining even his hoofs and his horns, for the Palladium, the root-word of "Palladism," is the grotesque figure with a goat's head, horns and hind legs, and a stomach covered with scales, which figured as Baphomet in the old witch Sabbaths and the secret rites of the Templars. The Palladists have seven sacraments. They have their *Pater*, their *Ave*, their *Gloria* (*Gloria Lucifero Victori*). They have their *Credo*. Here it is:—

"I believe in a begetting God, the principle of good, who from all eternity has opposed the destructive God, the principle of evil. I believe in imperishable humanity renewing itself through the ages. I believe in the future triumph of truth over falsehood, virtue over vice, justice over arbitrary authority, knowledge over error, liberty over despotism, reason over superstition, love over sterility, light over darkness, good over evil.

"I believe in the triumph of the great Architect of the universe, our God, over Adonai, the God of the Priests. Amen."

It is difficult to see in this all the diabolical wickedness that Dr. Bataille traces in it. This is the *Pater*. It throws light on Palladist methods and Palladist thought.

"Beloved Father, thou who livest in the heaven of fire, the home of eternal glory, the rule of worlds finite and infinite belongeth to thee, and thy name, the terror of the superstitious, is through the ages blessed by the initiates of pure heart. Long since thou mightest have scattered the hypocrites that worship Adonai, and regenerated the nations with thy religion, but thou art Spirit, Wisdom, Reason. Thou preferest that man of his own intelligence should discern the truth, and thou hast the patience of divine love. Thy will be done.

"Us, thy faithful flock, support in our struggle with the blasphemers of thy name, make thy light to shine in our hearts, restore day by day our bodies and souls, vouchsafing to us the benefits of health and material enjoyment, and the knowledge which begets progress. Be indulgent to our weaknesses if from time to time we neglect our duties, but punish without pity all treason. Preserve us from the corruptions of priests, and baffle their snares. Deliver us from Adonai. Amen."

The sacraments are:—

1. The Fire Baptism: lights are lit as in the illumination of the early Church.

2. *l'Armement*. At the first degree of the supreme rite the neophyte receives the symbolic arms.

3. The Heptagathon. Charity, the duty of succouring the "disinherited of fortune," etc.

4. Holy Sacrifice. This corresponds to the Catholic sacrament of marriage, but the Palladists are accused of having rather lax notions about the eternity of the institution.

5. Kiss of the Magus. With this kiss one of the high spirits is supposed to enter the body of the brother or sister.

6. The Eternal Pact. This corresponds, says Dr. Bataille, with *l'Ordre* of the Catholics, to the vow-taking of priests and nuns. Blood is let, and the Palladist signs the pact with this blood.

7. "Preservation" is the extreme unction of the Romish Church, the ear, the mouth, etc., are made safe against evil spirits by solemn rites.

It is to be seen at once that the Luciferism of Albert Pike differs from Satanism. Even Dr. Bataille (*Le Diable au XIX<sup>e</sup> Siècle*, vol. ii. p. 755) confesses that the rites are the rites of white magic not black. Miss Diana Vaughan tells us that Albert Pike was a zealous mystic, a strong medium, a Rosicrucian of the highest initiations. He

studied these mystical subjects with her father, who was a direct descendant of the "Rosicrucian Alchemist, Thomas Vaughan," about whom, however, she has made some strange mistakes. At the death of Albert Pike, Lemmi introduced as part of the ceremony initiating a *Maitresse Templière* the production of a genuine consecrated wafer which the lady was called upon to stab with a dagger. At once Miss Vaughan left the society, and started an independent periodical to advocate what she called the *bonne doctrine*, the worship of the "Dieu bon Lucifer." It was called the *Palladium Régénéré et Libre*. An interesting little work, *Le Palladisme*, by D. Margiotta shows (p. 48) that a fierce quarrel had sprung up between Albert Pike and Lemmi before this. The Italian mason had commissioned a poet named Carducci to write a "Hymn to Satan." This "was promptly sung in all the Italian Triangles."

The Palladists have litanies, the white mass, orisons. They have the "Gnostic sign of the cross." They have the scapulary, indulgences, *medailles bénites*. They have nuns (les Cypriennes) and convents. They have their "miracles." Dr. Bataille on this point records a quaint conversation that he had with Miss Diana Vaughan:—

"It must be understood that this lady, brought up in *Luciférianisme* from her tenderest years, rebuts with horror the charge of *Satanisme*. She considers us Catholics in flagrant error. The real Satan in her system is Adonai, the God whom we adore. We are the Satanists, and the miracles of Lourdes are the conjuring tricks of the devil. Diabolic possession must be sought amongst the Catholic saints, not in the 'Triangles' of the Palladists. For all that, Miss Vaughan venerates sweet, religious men like St. Vincent de Paul, who will, she holds, be happy for all eternity in the kingdom of *Dieu Bon Lucifer*" (*Le Diable au XIX<sup>e</sup> Siècle*, vol. ii., p. 848).

I must refer the reader to Dr. Bataille for a full account of the rites of Baphomet worship. The initiation of a Mistress Templar is one of the most imposing. If we may trust the somewhat crude photogravures of his work, the costume for gentlemen on this occasion is a dress coat,

a large battle-axe, and a white tie. Ladies are required to make themselves up as much like Greek goddesses as the modern balloon sleeves will sanction. The skirts must be looped up to expose the left leg as far as the knee. In the hall to the east is a baldachino with scarlet draperies covering the altar of Baphomet. The rest of the hall is draped in white with costly hangings.

Baphomet's altar mimics the Catholic altar very closely. It also has its tabernacle, with Jachin and Boaz for the columns at the little door. *Ordo ab Chao* is the motto. A two-headed eagle figures above.

The Grand Master and General Mistress, with all their "jewels," squares, levels, sit on a raised platform.

Sisters and brothers now form two groups—the "camps" they are called. Between these is the Pastos, a bedstead, Greek pattern. On this was a brother in a shroud counterfeiting Lazarus.

"Miss Arabella," the lady to be initiated, dressed in white, now appeared. She was put through a long catechism. She was then required to give the corpse a kiss, and say, "Lazarus, arise!"

The meaning of many symbols was explained to her. The barren fig-tree was the Papacy; the goat-headed God was "an emblem of power and fecundity." He "has the form of a he-goat, the figure of Pan. Between his two horns is the flaming pentagram, image of Divine light."

The Grand Master: "What is the name of the symbol of the temple in our liturgy?"

The Grand Lady-lieutenant: "Baphomet."

The Grand Master: "What is the secret of the formation of this mystical name?"

The Grand Lady-lieutenant: "Read backwards, it gives Tem. O. H. P. Ab."

The Grand Master: "What is the translation of that?"

The Grand Lady-lieutenant: "Templi Omnium Hominum Pacis Abbas."

We now come to the *Grande Rite*, the marriage of this world and the next. Certainly it throws a flood of light on some veiled passages which I have culled from the



writings of the Illuminati in my essay in the present volume. Thus St. Martin tells us that he has witnessed many spirit appearances in the *Martiniste* ceremonial. Lavater goes a step further and announces that no one can understand what the Christian "communion" really means unless he has seen the "Image," the "Symbol of the Lord," the "Spirit of the Lord," appear bodily at their holy rites. The customs of the Palladists explain all this. Lights were put out when "Miss Arabella" was received as a Mistress Templar, and all sate in silence.

Then suddenly the altar of Baphomet shone in a light far more brilliant than the most brilliant electric-light, and the throne of the Grand Master shone out likewise, making up, with the details around, a great head of a demon. By-and-by a figure appeared, but Dr. Bataille was sure that this was the Grand Master covered with phosphorus, and not Baphomet. But he tells us that when novices are present it is customary to give sham phenomena, but with the fully initiated the real "Lucifer" appears. The doctor gives an account of one of these "miracles of the devil." He appeared as a radiant young man. Miss Diana Vaughan tells us that at her first initiation the statue of Baphomet at the altar became animate.

The most absurd rites and customs had once a logic. The popular devil with horns and hoofs is not the great adversary of Scripture. He comes from an earlier religion. The best informed writers assure us that he is Pan. When Christianity tried to burn completely out the earlier worships, secret meetings in woods and wastes became a necessity. Then, in process of time, Pan, the god of the woods, was taken over as the Christian devil, and was also made Baphomet, the ideal head of Christian revolt. When monks are dominant and faggots are plentiful reformers play a game whose counters are human lives. It was necessary, in consequence, to protect their secret meetings from treachery and from the confessional. This suggested rites of initiation on the surface so revolting that it was judged the priests would never forgive them even in an informer. Hence the

obscene homage to Baphomet, the pact signed with blood, the outrage to the sacramental wafer. Writers abroad trace Masonry through the Templars to manichœism and gnosticism. I show this further on in my essay on the *Illuminati*. The password to the witches' Sabbaths was "Toledo," as Michelet shows. This was because Toledo was the headquarters of two schools of magic—the Jewish Kabbalists and the Sufis; the Jews and the Mussulmans being the only two independent religious bodies outside Christianity in Europe. The Mussulmans had a mystical society, the Sebiin, or the Society of the Rose.

"According to his progress in the way," says M. Napoleon Ney (*Les Sociétés Secrètes Musulmanes*, p. 14) "different names were given to the neophyte." He was first *Talamid* (disciple or servant), then *Murid* (aspirant). He was then initiated and became *Fakir* (beggar, Ebronite the Buddhist, *Bhikshu*). He was then *Sufi* (seer, according to M. Ney), then *Salik* (walking in the "way"), then *Mejedub* (drawn to God). There are two higher degrees reached by few *Mohammedi* (full of the spirit of the Prophet), and *Tuhidi* (merged in the Divinity).

The rose is the Indian lotus in western mysticism and also western art. In some societies, says M. Ney, to "receive the rose" a noviciate of a thousand and one days is required, during which the aspirant is condemned to the meanest duties of the household and to painful and degrading ordeals. "In the hands of thy Sheikh thou shalt be as a corpse in the hands of those who wash dead bodies!" This reminds M. Ney of the *perinde ac cadaver* of the Jesuits.

"What rose do you wear?"

"The rose of Mulai Taieb."

If this answer was given, the questioner knew that he was in the presence of a high initiate.

From this Society of the Rose, which was (and indeed is) very active in its propagandism, waves upon waves of mysticism have come to the west: the Rosicrucians, the *Illuminati* through Schrœpfer and Kolmer, the *Martinistes* through Martinez Pasqualis. "The Rose" was the fine interior religion of Saint Martin.

Here a pregnant question arises: If earnest thinkers

like Albert Pike and the brothers Vaughan wanted to spread this fine interior religion, why did they add to their new "Palladism" the rites of Macbeth's witches? Albert Pike was a man with mind culture above the average, with soul culture above the average. He had served with credit as a general during very real war: this implies a genius for organization, a nice adjustment of means towards the end desired. If such a person desired to make his neighbours seek God in the heart rather than in credos and "articles of religion," where was the logic of the pact in blood with a goat-headed monstrosity? The only answer is that Baphomet and his ritual was already there. The lady Palladists and their quarrels have laid bare the secrets, well kept hitherto, of the Rosicrucians, the *Martinistes*, the *Illuminati* of the French Revolution.

1. The name suggested for the new religion was Palladism, making the Palladium or Baphomet the cornerstone of the Temple.

2. In Charleston is the largest Masonic temple in the world. In this, worshipped like the true cross amongst Catholics, is a rude sculpture said to be the actual Baphomet once in possession of the Templars.

3. Eliphas Lévi gives a formidable portrait of Baphomet as the frontispiece to his *Dogme de la Haute Magie*. Eliphas Lévi was the head of the *Martinistes*, after the death of Saint Martin. He confesses (chap. xv., vol. ii.) that from the date of the Templars until "perhaps our own days" this goat-headed monster has figured. With the vulgar he was the devil, and was honoured with lewd rites. With "real adepts" he represented the god of Spinoza, Plato, Saint Martin. Who were the "real adepts"?

4. The Abbé Fournié, who was deeper in the magical secrets of Martinez than anybody else, was plainly a strong medium. He evoked numbers of spirits. All these were the ghosts of dead mortals, he said, except one mighty figure. He had never lived on earth. *Lux e tenebris* was the pass-word of the *Chevaliers d'Orient* amongst the *Illuminati*. Dr. Bataille connects together this motto, this mighty apparition of Fournié and the

luminous figures that emerged from darkness in the Palladist grand rite. He might have added Lavater's "Image," the symbol of the Lord.

I have already mentioned that M. Papus has given an answer to all this in a pamphlet, *Le Diable et l'Occultisme*. M. Papus represents the *Illuminati* of last century. He took over *Martinisme*, Rosicrucianism, ceremonial magic from the celebrated Eliphas Lévi, the successor of Saint Martin. We have said that Palladism is the theology of Saint Martin joined to the demoniac rites of the Witches' Sabbath. I opened the pamphlet of M. Papus with eagerness. He of all people could tell us if this was true.

The result was eminently disappointing. The pamphlet through eighty-six pages discourses on God in the manner of a prize essay, but studiously avoids the subject of Baphomet and his pacts with suspicious alertness. M. Papus holds, if I understand him aright, that Satan worship, Lucifer worship, Palladisme are all non-existent. The black mass has been "imagined by M. Huysmans." "It is only a few brave priests and miserable women who have really believed that Lucifer appears to Parisians." The whole movement is the "issue of the sacristies." It is a commercial speculation of Catholic publishers at a time when the market is depressed.

But does this theory quite fit in with the facts? There are five temples of Satanism in Paris itself. Do the Catholic publishers run these? Satanism has the *Bulletin du Diable* and other organs.<sup>c</sup> Are these the issue of the sacristies?

The subject has recently been made prominent by a great trial in the French Law Courts, and it seems to me that theories like that of M. Papus are no longer tenable.

A writer in the *Globe*, April 30th, 1895, gives details of this curious case:—

"Lovers of the occult sciences are looking forward to a strange libel case, which will shortly come before the Paris tribunals. It is brought by a Mlle. Lucie Claraz against a fantastic publication called the *Revue du Diable*. The suit in itself is not of any importance, but it will be

rendered curious and interesting by the production of a number of documents concerning the two mysterious sects known as Luciferism and Satanism.

“At Bulle, not far from Fribourg, a barrister, a confirmed anti-clerical, a well-educated man, and fond of studying things philosophical, opened his house as a freethinking club, which was soon transformed into a Masonic lodge, entitled ‘La Réformée,’ and placed under the direction of Mons. Steckelin. The lodge was composed of noted and respected persons. In a short time they began to take an interest in Luciferism, and Mons. Steckelin, after having converted his brethren, undertook to celebrate the Luciferian ceremonies with all the pomp with which the Catholic churches surrounded the cult of Adonai. He forthwith bought a garden in the Rue de la Grande-Fontaine, at the bottom of which were the remains of a granite cliff. Out of that cliff he cut a subterranean temple, similar to that of Albert de Rudolstadt in the ‘Consuelo’ of Georges Sand. This Luciferan sanctuary was fitted up in Roman style. It contained two large square altars, one for the sacrifice, and the other for masses, with three small ones in the form of triangles, destined for other ceremonies. The choir was perched above in a gallery shut out from the public gaze. Conspicuous in the services was the ‘Grande-Maitresse.’ In religion she was called ‘Deodata-Lucif.’ She was accompanied by a procession of ‘sisters,’ whose co-operation was necessary in the celebration of the mysteries of Lucifer, the God of Joy and Pleasure. The question was soon raised who was the lady hidden under the sacred name of Deodata-Lucif? The good people of Fribourg at once said it was Mlle. Lucie Claraz, notwithstanding that she was more fit to be the servant of a curate than a priestess of Lucifer. She was forty-five years of age, very thin, with sunken eyes and protruding lips. She lived in the house of Mons. Stekelin, her brother-in-law, and was regarded as a most ardent Catholic. One day she wrote a letter to the bishop of the locality, denouncing the abominations of which the Luciferan temple was daily the theatre. Aided by the alms of indignant Catholics, and subscriptions from Italy,

France and Belgium, she bought up the garden, together with the temple, and announced her intention to found a religious order on the spot, in expiation of the sacrileges which had been committed there. The Patriarch of Jerusalem, it is said, was so pleased with her zeal that he sent to her the decoration of the Holy Sepulchre."

So far Mlle. Lucie Claraz succeeded in carrying out her scheme; but, unfortunately, a change in the scene took place. "At the moment when the funds collected by her began to flow in from all quarters," says the writer in the *Matin*, who is responsible for these details, "the financial situation of the Luciferians was in a desperate state. The converts to the Good God refused to pay their share of the expenses caused by the construction and establishment of the temple. Mons. Steckelin had no money. The creditors thereon seized all the holy objects used in the ceremonies, and the mystery was exploded. Here Mlle. Claraz stepped in and paid the debts of the High Priest of Luciferism, her brother-in-law, but with the funds subscribed by the faithful for the creation of a new religious order. Naturally there was a great outcry among the clergy when they learned to what use the subscriptions had been put. The curate of Gruyère refused to admit her to the Holy Communion, and she brought her appeal before the ecclesiastical authorities, but to no purpose, and she was condemned to pay the costs. The singular case was published at the time in several papers. As regards the reports that she acted as Grande-Maitresse in the Luciferan services, she stoutly denies it. It is probable it was due to the circumstance that her brother-in-law was High Priest of the sect. What has become of him is not stated. Such," says the writer in conclusion, "are the facts which will be laid before the Paris tribunal. It remains with the French law to decide if Mlle. Lucie Claraz was libelled when she was accused of having filled the part of the mysterious Deodata-Lucif." Many more curious details relating to the affair are expected to be made during the trial, in which the Luciferans and the Satanists will probably be examined in respect to their extraordinary

aberrations of religious sentiment and the mystic doctrines which they profess to hold.

The case of Mlle. Lucie Claraz came up eventually in the 9th *Chambre Correctionnelle de la Seine*. The Judge was M. Bidaut de l'Isle. The celebrated M. Clunet was the lady's advocate. He claimed 5,000 fcs. damages for the libel.

"The audience," says a French report, "were transported into the Temple of Satanism, into those accursed haunts where, before the image of Satan, were performed the most monstrous of rites and the most indecent of orgies. A passage from the *Bulletin du Diable* was cited, which announced that the black mass, full fledged and robust (*bel et bien*), was performed in four or five places in Paris alone, and that the worship of the Evil Spirit had many votaries."

The counsel for the defence took the line that this devil-worship was non-existent, and that, therefore, to accuse a person of an impossible offence was practically no libel at all. But the judge, who heard all the evidence, gave full damages to the plaintiff. This is important. He at least believed in the existence of the Black Mass.

I have called Palladism a combination of freemasonry and modern spiritualism. Hence its great success. The lady "mediums"—it is Albert Pike's own word—seem to differ in nothing from other mediums. Each has a *daimon protecteur* corresponding to the "control" of Eglinton or Home. Miss Ingersoll has Behemoth. Miss Diana Vaughan has Asmodeus. A lady friend of hers has for control, and even husband, Milton's—

"Moloch, horrid king, besmeared with blood  
Of infants' sacrifice and parents' tears."

At the villa of Monte Caprino, on the lake of Lugano, Dr. Bataille saw some of the miracles of Miss Sophia Walder. When he knew what spirit really controlled her his breath was fairly taken away.

"Rigid as an automaton she stretched out her left hand, and on the open palm I saw appear, one by one

under the skin, these letters: B, A, A, L, Z, E, B, O, U, B."

These miracles of the villa of Monte Caprino the doctor describes. There was a dinner, and the *séance* was after dinner at the Villa, and not in the ordinary "Triangle." He does not say that the usual battle-axes and masonic jewels were *de rigueur* on the occasion. Sophia materialised a *beau jeune homme* in Greek armour.

"Who are you?" said the Grand Master,

"Alexander III. of Macedon."

Then came Luther, Cleopatra, Voltaire, Garibaldi, and others.

All this is very like the spiritualistic *séance*; and it is announced that Miss Sophia Walder will not now evoke or "fluidify" under a fee of £200. In her fluidifications she passes through a wall and disappears. Miss Diana Vaughan exhibited a similar miracle, for, summoned to a Triangle in France, she arrived quick as a flash of light from a distant spot in Russia. During a picnic to the Mammoth Cave, Kentucky, Miss Vaughan showed a greater miracle. Summoned by Asmodeus, she passed the lake without wetting her feet, walking on the water.

The apostles of ceremonial magic, Eliphas Lévi, Papus, and others, are never tired of announcing to Spiritualists like Professor Crookes and Mr. Vincent Wallace the extreme danger of dabbling with psychism without Kabbalistic checks and traditional rites. A spirit comes to a *séance* of Professor Crookes and calls itself "Katie King." It is not Katie King we are told, but a "spook," a "shell." But, on the other hand, how can we be quite certain that B, A, A, L, Z, E, B, O, U, B, really comes to Miss Walder, or Asmodeus to Miss Diana Vaughan? As a necessary preliminary it would have to be proved to us that such evil spirits have ever existed outside the Ingoldsby Legends:—

"And he bounded away, like a football at play,

"Till into the bottomless pit he fell slap,

Knocking Mammon the meagre o'er pursy Belphegor,

And Lucifer into Beëlzebub's lap."



Also is it a proof of quite the highest wisdom in the adepts of Martinism and Palladism, their retaining Baphomet and his rites, as a preliminary to the study of internal religion. The vulgar call him the devil, says Eliphaz Lévi, but real adepts see in him the God of Saint Martin. Just so. But the vulgar usually prevail on these occasions, and the *Satanistes* with their wafer daggers, Priapic anthems, Hymns to Satan, and rumours of secret murders, seem already to have swamped up the more philosophic *Luciferistes*.

Miss Diana Vaughan, according an interview to M. Lautier and Dr. Bataille, gave them the following figures:—

Masonic "Adepts" in the world . . . . .	19,136,228
Female Adepts . . . . .	2,725,556

Of course most of these are harmless masons, but the total of female adepts give some idea of the lengths to which Palladism has already spread. M. Huysmans, who has brought forward the evidence against the Satanists in a sober preface to a work by M. Jules Bois (*Le Satanisme et la Magie*), as well as in novels, announces that the robbery of the consecrated wafers in churches has reached an "incredible development."

On the Tuesday of the Holy Week last year an old woman stole from a chapel of Notre-Dame two pyxes, each containing fifty consecrated wafers. M. Huysmans gives a long list of the robberies in other parts of France, and says that Italy has a similar experience. "In the Holy Week all the consecrated wafers in the monastery of *Notre Dame des Sept Douleurs*, in Rome, disappeared, as also in the parish church of Varese in Liguria, and the nunnery of *Santa Maria delle Grazie* at Salerno."

Why these robberies? A pyx is of no value at a pawnbroker's, as it would have to be melted down, and the police have found no trace of these stolen vessels. "Plainly they were abstracted," says M. Huysmans, "for the orgies of the black mass." At Port Louis in the Mauritius the *Satanistes* go a step further and murder

black children for their foul rites. M. Huysmans gives names and dates.

I must mention that in my first chapter my sketch of Swedenborg is prefaced by a short biography by the famous M. Balzac.

Sri Basanti Bhattar Sec.  
41-A, Malabar Road, Madras 5.  
NOT EXCHANGEABLE  
NOT SALABLE

## MODERN MYSTICS AND MODERN MAGIC.

---

### CHAPTER I.

#### SWEDENBORG.

**E**MANUEL SWEDENBORG was born at Upsala, in January, 1688, according to some authors—in 1689 if we may trust his epitaph. His father was Bishop of Skara. Swedenborg lived eighty-three years, and died in London, March 29th, 1772. I use these words to express a simple change of state. According to his disciples he was seen at Jarvis, and in Paris after this date.

The life of Emanuel Swedenborg must be divided into two parts. From 1688 to 1745 the Baron Emanuel Swedenborg appeared in the world as a man of vast knowledge, esteemed for his virtues, always irreproachable, constantly useful. In addition to his important official duties in Sweden, he published from 1709 to 1740 many solid works on mineralogy, physics, mathematics, and astronomy. He designed dry docks for vessels. He broached difficult questions, such as the height of tides and the position of the earth. He invented improved locks for canals, and new processes for the extraction of metals. When in 1785 an European discussion arose on the subject of the experiments in animal magnetism in Paris, the Marquis of Thomé avenged the memory of Swedenborg. The Commissioners named by the King of France had asserted that there was no theory about the magnet; whereas Swedenborg had thoroughly discussed the subject in the year 1720. M. de Thomé took advantage of the occasion to point out how modern celebrities banished the clever Swede to studied oblivion in order that they might steal his treasures for their own

work. "Some of the most illustrious," said the Marquis, alluding to Buffon's *Théorie de la Terre*, "strut in the plumes of the peacock without doing him honour." And drawing on the encyclopædic works of the learned Swede, he showed how this great prophet had anticipated by ages the march of human knowledge. He was the forerunner of modern chemistry, having shown that the productions of organic nature are all decomposable and resolvable into two pure principles; that water, air and fire are not elements. And in one work, in a few words, he went to the bottom of the mysteries of animal magnetism, and snatched from Mesmer the credit of the first discovery.

In the year 1740 Swedenborg preserved a complete silence. Out of it he emerged in 1745 to devote himself entirely to the world of spirit. Thus he describes his vocation. One night in London when he had dined copiously, a thick mist spread in his room. Then a being exclaimed, in a terrible voice: "Do not eat so much!" The next day he ate less. At night the same being arrived, an angel clothed in purple and bright light. "I am sent by God," he said, "Who has chosen you to explain the meaning of His word and His works. I will dictate what you must write!" That night the eyes of the *interior man* were opened, and he was able to see into heaven, hell, and the spiritual world, three separate spheres. There he met old acquaintances who had died, some recently, some long ago. From this moment Swedenborg constantly lived in the world of spirits. He remained in this present world like one who had a mission from God. This mission was questioned by sceptics, but his conduct was plainly that of a being superior to ordinary humanity. Also, although his fortune was meagre, he gave enormous sums to save from bankruptcy commercial firms in many lands. None who appealed to his generosity were disappointed. An incredulous Englishman pursued him and overtook him in Paris. He has recorded that in his house the doors remained constantly open. One day the servant complained of this negligence, which might expose him to suspicion in the event of any robbery occurring. "Let him not be alarmed," said Swedenborg, "his mistrust is pardonable. He does not

see the guardian that keeps watch at the door." In point of fact, he never, in any country, closed his doors, and never lost anything. At Gottenburg, on the occasion of a great fire at Stockholm, he announced that fire three days before the arrival of the courier with the news, and remarked that his own house had escaped. This also proved true.

At Berlin the Queen of Sweden told her brother, the king, that one of her ladies had been cast for a sum which she quite knew that her husband had paid before his decease. Unable to find the receipt, she went to Swedenborg, and desired him to ask her husband where he had deposited it. Next day, Swedenborg told her the spot, and announced that, according to desire, he had begged the dead man to appear to his wife. In due course of time he came in vision, attired in the dressing gown in which he had died. One day, embarking in London, in the ship of Captain Dixon, the gifted Swede heard a lady ask if there were sufficient provisions in the vessel. "More than enough," said Swedenborg, "in eight days at two o'clock we shall be in the harbour of Stockholm." This occurred. The lucid state into which at will he could throw himself when dealing with earthly matters, although it astounded his friends, was as nothing compared with his power of travelling in the astral regions. The description of the first flight of Swedenborg guided by an angel is of a sublimity which far surpasses the best work of Klopstock and Milton, of Dante and Tasso. This passage which prefaced his work on *The Astral Regions* has never been published. It belongs to the traditions confided to the three disciples for whom he had most affection. The speech in which the angel proved to the Swedish seer that the stars are not made to wander about unpeopled in the skies reaches a grandeur of divine logic unknown to man. I cannot narrate all the facts of his visible and material existence. His habits opposed such knowledge. He lived a secluded life, without any desire to obtain riches or celebrity. He had a great personal repugnance to make proselytes. He opened his mind to few, and communicated his special gifts only to those who professed faith, wisdom, and love. By a look

he could tell the state of the soul of a stranger. He could impart the gift of clairvoyance to those whom he wished to instruct in interior knowledge. After the year 1745, his disciples never saw him perform any action from a mere human motive. "In one hundred years," he said to Mons. Ferelius, "my doctrine will rule the Church." He predicted the exact day and hour of his death. On Sunday, March 29th, 1772, he asked what time it was. "Five o'clock," was the answer. "Ah! then, all is over; God bless you all." Ten minutes after this he passed away. Some folks believe that Swedenborg had real visions of heaven, but that divine inspiration is not in all his writings. Poets admire his wonders: To the seer all is pure reality. Pious Christians were shocked at much. The sceptics made fun of his golden palaces, and the too great abundance of chalcedony, chrysolite, carbuncle, and beryl, in the heavenly buildings. He announced that colours in the spirit world could sing, and precious stones, like the Urim and Thummim, give intelligible answers to questions. His disciples, in defending him, pointed out how he had himself met similar objections by citing the words of Jesus (John iii. 12): "In teaching you I made use of earthly phrases, and you understand me not. If I spoke to you the language of heaven how could you understand me?"

I must remark that I have condensed Balzac a little, whose narrative here terminates.

After his death the writings of Emanuel Swedenborg were for a long time quite as little heeded as when he was alive. In about twelve years time an English printer, named Hindmarsh, formed a small "Theosophical Society," having become interested in Swedenborg's writings. This by-and-by developed into the "Lord's New Church," with a ritual copied from the Church of England, and with the sacraments of baptism and the eucharist. This Church had ministers properly ordained, bishops, priests, pastors. It had rules of faith, and a very definite description of God. It affirmed that Jesus, through Swedenborg, had given for the first time the true Christian revelation. *The New Church Messenger* (New York, December 21st,

1887), writes thus :—" All New Church papers accept the writings of the New Church as a Divine revelation." The *New Church Life* goes a step further and says :—" Consequently they are an infallible Divine authority."

One hundred years have passed. Has the Lord's New Church, according to prophecy, invaded the world? Its members are obliged to confess that outside America and England it is almost unknown, and that its progress since the days of Mr. Hindmarsh has been insignificant.

Does this mean complete failure? A great wave of psychic knowledge has come upon us since the days of Swedenborg. We now can see some matters in a different light.

In the first place, we see that the New Church began proceedings at the wrong end. In his excursions to the Astral Regions, Swedenborg had reported that he had met many dead friends. These dead friends were like his living friends in this, that they still held divergent views about the nature of God, the condition and prospects of the saved, the condition and prospects of the damned, and so on. It was possible from these to select ideas that on most points clashed little with the dominant creed. It was possible also to select ideas that warred with it completely. The New Church made its selection from the first group of ideas, thus making the views of the day, and not Swedenborg, the real Revelator.

Swedenborg has affirmed that he received his revelation direct from Jesus. But he also writes thus: "When spirits begin to speak with a man, he ought to beware that he believes nothing whatever from them, for they say almost anything. For instance, if they were permitted to describe what heaven is, and how things are in the heavens, they would tell so many lies, and indeed with solemn affirmation, that a man would be astonished. Whenever any subject of conversation is presented, they think they know it, and give their opinions upon it, one in one way and another in another, quite as if they knew. For example, if they were permitted to tell of things to come, of unknown things in the universal heaven, of anything whatever that a man desires, while speaking from themselves they would not speak the truth, but all things

falsely. Let men beware, therefore, how they believe them. For this reason the state of speaking with spirits on this earth is most perilous, unless one is in true faith. They induce so strong a persuasion that it is the Lord Himself who speaks and commands, that a man cannot but believe and obey" (*Spir. Diary*, n. 1622).

But this, of course, suggests a question. If spirits are so fond of personating Jesus, how can we be sure that Swedenborg himself was not deceived? He had "true faith," his followers answer promptly. "But what was this "true faith?" Not the Catholic, for he has recorded that the Roman Catholic religion is Babylon, the Harlot drunk with the blood of the Saints. He has also announced that the Protestant Churches of his day were full of "falsities." All the Protestants believed in three Gods. They alleged that everything was made out of nothing. They failed to see that God was the one Substance of the Universe. Their conception of salvation by the atoning blood of Christ was degrading to the idea of a God. "It is a contradiction to say that Mercy itself or Good itself can look upon man with anger and decree his damnation, and yet continue to be his own divine Essence" (*True Christian Religion*, 132). Indeed, in one passage in his *Spiritual Diary*, Swedenborg goes so far as to say that the iniquity of those called Christians is consummated, wherefore the Lord's Kingdom is now turned to others (*S. D.*, 2,567). On another point the Lord's New Church have decidedly not chosen the best of two contradictory teachings of Swedenborg. He is always represented in the works distributed gratuitously by the Swedenborg Society, as having proclaimed that the punishments of hell are eternal (*Arcana Coelestia*, 7,541, *et passim*). And yet he says very distinctly (*Spiritual Diary*, 4,596), "The angels continually hold the hells in subjection, and temper all things there, and this from the Lord. Otherwise the tortures would be perpetual."

Again:

"It would be unreasonable to suppose that the Lord would permit any one to be punished in hell to eternity for the sins of a short life" (*Spiritual Diary*, 3,489). He



says, too, that punishment is only with a view to reformation (*Ib.* 3,489), for nothing in the law is ever without a use (*Ib.* 3,144).

In point of fact, the New Church has been looking out for a verification of Swedenborg's prophecy quite in the wrong direction. One hundred years have passed, and his descriptions of the next world have influenced all the Churches, even the Roman Catholic. He was a great psychic, and not a great creed maker.

What did folks in England believe about the unseen world one hundred years ago? It was held that the soul went with the body into the coffin, and remained in a torpid state in the cemetery until a very material trumpet should sound, to summon it to a great assize. The mighty dead were all mindless, and heaven was peopled by certain "angels," beings who had never been schooled by joy and pain, beings who had never been tempted, beings who had never resisted temptation, beings with wings, beings as faultless, but also as mindless, as the stone angels that represented them on tombs erected by the undertaker.

But some will say, "That is the view of the next world that is held by the Low Church! Cardinal Newman, in his fine poem, 'The Dream of St. Gerontius,' has dissipated that!"

The poem named has been most eagerly devoured. With Roman Catholics and with the English High Church party it has almost superseded the New Testament as a revelation of the Unseen World. Let us examine it with some care.

The poem opens with a picture of St. Gerontius on his death-bed. The last rites of the Church are performed. Prayers are asked from mortals, and also from the "Choirs of the Righteous" in heaven, from St. Peter, St. Andrew, St. John, from "holy hermits," and so on. The saint dies; and soon he finds himself rushing swiftly through the air, borne on the "palm" of an angel to the Throne of God. This angel is not very much superior morally to the angel of the tombstones:

"Is it a member of that family  
Of wondrous beings who, ere the worlds were made,  
Millions of ages back, have stood around  
The throne of God? He never has known sin."

What sort of body does the saint possess? Oddly enough, he possesses no body at all.

“Nor touch, nor taste, nor hearing hast thou now;  
 Thou livest in a world of signs and types,  
 The presentation of most holy truths,  
 Living and strong which new encompass thee.  
 A disembodied soul, thou hast by right  
 No converse with aught else beside thyself,  
 But lest so stern a solitude should load  
 And break thy being, in mercy are vouchsafed  
 Some lower measures of perception,  
 Which seem to thee as though through channels brought,  
 Through ear, or nerves, or palate which are gone,  
 And thou art wrapped and swathed around in dreams.”

This is a little bewildering. Philosophers tell us that you cannot bottle up that tiny portion of the divine essence which we call a “soul” without a body of some kind. The dead body of the Low Church seems better than no body at all. Then, how did the angel bear St. Gerontius in his “palm” if there was nothing to bear? How, too, did the “holy hermits” and the “Choirs of the Righteous” pray for him without lips? The choruses of the souls in purgatory sound out in the poem. How can the “sulphurous and tormenting flames” properly scorch out their sins if there is no body to scorch?

But a more crucial question is behind. If there has been no “Day of Doom,” how can it have been settled who are in the “nethermost hell,” who are in purgatory, and who swell the “Choirs of the Righteous?” The answer is quite astounding. There is a rehearsal of judgment.

“Already in thy soul  
 The judgment is begun. That day of doom,  
 One and the same for the collected world,  
 That solemn consummation for all flesh,  
 Is in the case of each anticipate  
 Upon his death; and as the last great day,  
 In the particular judgment is rehearsed.”

Can the reason of man grasp this? Let us suppose that Sir Henry Hawkins or Mr. Justice Day were asked by a royal personage to rehearse a murder trial for the benefit of an Eastern visitor. What would be the answer?

“Your Royal Highness, you ask for two trials of one criminal. The idea is inconceivable. One of these must be real, horribly real, for the evidence is strong. In it I must most probably put on the black cap, and in solemn words consign a human being to death and the judgment of God. These solemn words in one of these trials will be pure comedy, in the other I might as well sing them to comic music in an opera by Gilbert.” And yet in the view of Cardinal Newman the Maker of the million million starfy systems is capable of similar ignoble histrionics.

When a picture is discovered, say a “new Raffaele,” experts compare it at once with his known work. Has it the same principles of composition, the same masterful adjustment of details? We have a picture of a world said to be by the Great Artist that composed this world. Will it bear the same test?

Here man is amongst surroundings that exactly suit him. He has a soul enclosed in a body, hearing, sight, and other delicate senses. A beneficent warning has been designed to tell him when his physical health is menaced, namely, pain; another, when his moral health is menaced, namely, sorrow. And as the advance of the race is as much an object with God as the advance of the individual, disease is not confined to one alone. Germs spread it, and all are powerfully urged to help their neighbours. Thus there is constant improvement.

Now in the spirit world, seen by Swedenborg, this intelligent system is reproduced. A man has a living body, not a dead body, or no body at all. His mind, instead of having a “lower measure of perception,” like St. Gerontius, is cleared. Progress, instead of being arrested, goes on for ever. Pain is still beneficent and useful, not useless and cruel. A stronger point remains:

Much has been written lately about what the Duke of Argyll happily calls the “Husbandry of Heaven.” The mechanism of Providence, as we see it on this earth, is a perfect mechanism. The minutest cog-wheel does double and triple duty. All is simplified. There is no waste of energy. In this mechanism the amelioration of man is effected *en bloc* by gradual evolution, the stronger

helping on the weaker with their superior experience and intelligence. 'Why should Providence in the next world suddenly completely dislocate this perfect mechanism, and instead of utilising this large helping multitude of dead men grown wise, should shut them all up in boxes in cemeteries, and create a vast army of exceptional beings, omniscient and omnipotent perhaps, but quite unable from experience to deal sympathetically with human weaknesses ?

I have here sketched Swedenborg's celebrated doctrine of "Concordances." As a scientist he saw very plainly that if there is an unseen world, in its larger characteristics this world would be like it, the "pattern" of heavenly things, as the author of the "Epistle to the Hebrews" puts it.

Swedenborg, though groping a little in the dark, was the originator of experimental occultism.

1. He judged that there cannot be two large laws, that the great law of the seen and the unseen world must be identical.

2. He judged that we must treat man's visions scientifically.

A being not of the earth appears. It takes the form, let us say, of the dead Swede mentioned in Balzac's biography.

What is it ?

"A wicked elementary, masquerading !" say the Kabbalists. "The devil himself !" says Catholic orthodoxy. "Brain disease !" say the disciples of Psychic Research.

Swedenborg, accustomed to scientific processes, cross-examines the ghost. "Where is the document your wife is seeking ?"

The ghost tells him, and the document is found.

## CHAPTER II.

### BOEHME.

SIDE by side with the experimental runs the intuitional occultism, two schools opposing, but as I think helping each other. To this second school we owe much in these days, represented as it is by subtle thinkers such as Anna Kingsford, Mrs. Penny, Miss Lord. They have strongly protested against the dangerous levity and vulgar love of marvel of many "Spiritualists." The mighty change in the breast of man from matter to spirit is not a mere pastime. Let us deal with the great apostle of intuitional occultism.

Jakob Boehme was born at Alt Seidenberg, in Upper Lusatia, in the year 1575. This is a straggling hamlet ten miles S.E. of Gorlitz. He was first of all a herd boy, but at the age of fourteen he was apprenticed to a shoemaker. Being one day alone in the shop, an old man, of imposing aspect, entered. He wanted a pair of shoes. When he had paid for them he left the shop, and from outside called out in a loud voice, "Jakob, Jakob, come here!" Astonished to hear his Christian name from the mouth of a stranger, Jakob went out.

"Jakob," said the stranger, with a look in his eye that alarmed the young shoemaker, "thou art of small importance, but thou wilt one day be great, and the world will be astonished. Fear God and read His Word. In it thou wilt find consolations, for suffering will be thy lot. Misery, poverty, persecutions will assail. Trust in God."

Part of this prophecy was only too quick in its fulfilment. For Jakob having tried to improve his brother cobblers, who were a little too fond of loose talk and swearing, was sent adrift by his master. Wranglings

had taken place, and that worthy said that he could not harbour a "house prophet."

Jakob, now in great straits, eked out a little money as a travelling journeyman. He was very unhappy; and religious doubts assailed him. At length he had a strange experience. For seven days he "was lifted into a Sabbath of the soul," says Bishop Martinsen. That means that his interiors were opened. He himself described it as a "Resurrection from the Dead."

In the year 1610 he had another and "fuller inward experience. What he had before seen chaotically and in fragments he now saw as a harmonious whole. It was a panorama of the mysteries, the *Ungrund* or stillness where dwelt the Father, the Son, and the Holy Ghost before the creation; the birth of the stars and the world; the creation of the angels and their great defection. For memory, and not for publication, he wrote it all down. His original title was the *Morning Redness*. Jakob said that he was not master of himself when he wrote.

A nobleman, Carl von Endern, chanced to see this MS. His admiration was unbounded. He had several copies made. This was unlucky. A stern clergyman, the Pastor Primarius, saw one of them. This man, whose name was Gregorius Richter, immediately fulminated in the pulpit about "false prophets." Jakob tried to conciliate him, but found himself accused of heresy before the civil powers. The magistrates dismissed him with a caution that he must never again thus offend. And they made him give up all his MSS.

Jakob had a valuable friend, Dr. Balthasar Walther. This gentleman was a profound student of magic, which study in those days meant the Kabbalah. Dissatisfied, he had "travelled in search of ancient magical learning through Egypt, Syria, Arabia, etc." Jakob at this time was very melancholy. Under Walther his inner life was developing, and the inner and the outer were at painful strife. His visions continued. He thought by his silence that he was obeying man rather than God. He wrote *The Way to Christ*. This was printed without his knowledge. Again the Pastor Primarius was active. This time Jakob was banished. But a curious retribution

overtook the good Pastor. His son became a prominent disciple of Boehme, and helped to copy and spread his works.

We have seen that Jakob was initiated into the secrets of the Kabbalah by Dr. Walther.

What was the Kabbalah?

The Kabbalah is a book of magic, a book of lofty mysticism, a book of quite astounding pretensions.

It is said to have been dictated by God Himself to a "select company of angels who formed a theosophic school in Paradise." It was revealed to Adam, and then to Noah, to Abraham, to Moses. It was the secret Wisdom of Israel handed orally down with immense precautions.

With greater plausibility it is asserted to have been a secret book of the Essenes and Therapeuts, the section of Israel that derived their mysticism from contact with the Buddhist missionaries. It is said to have been in the hands of Jesus and His disciples. Distinct traces of its teaching have been alleged in the Apocalypse and the Pauline epistles.

"But we speak the wisdom of God in a mystery, even the Hidden Wisdom which God ordained before the world to our glory" (1 Cor. ii. 7).

But its astounding pretensions do not end here. It was written down from tradition by one Moses de Leon, who died in Spain A.D. 1305. Once more it had a powerful effect. It converted Jews to Christianity. It laid the seeds of the Reformation. It has been the Book of Magic of a long line of mystics and magicians—Raymund Lully, Reuchlin, Von Helmont, Picus di Mirandola, Cornelius Agrippa, Paracelsus, Boehme. These mystics had for descendants the famed *Illuminati* of Germany, who are credited with the French Revolution.

First, as to its date, there are three theories that may be stated:—

1. It is held by Kabbalists, *pur sang*, to be a purely Jewish work, existing long before the Essenes or Buddha were heard of.

2. Dr. Ginsburg and the fashionable school of modernisers hold it to be a forgery, the original composition of Moses de Leon, who died A.D. 1305.

3. The third theory I have already stated. I hold that it was one of the secret books of the Essenes. I have brought this forward in my *Buddhism in Christendom*.

One point alone seems fatal to the first two theories. With the one exception of the Essenes, all Jews are and have been abject slaves of the letter, the most stiff-necked of Bibliolaters. How could they have cherished a work whose main teaching is that the letter of the New Testament must all be explained away?

A second objection may be stated.

The Jews were stubborn unitarians, and quite hated the Trinity idea. The Zohar proclaims the Trinity of Philo, the Trinity of Buddhism.

It announces that for millions of millions of years En Soph (the Boundless), the formless, passionless, inconceivable, inactive God remained quiescent and solitary in chaos. Then, by the aid of Sophia (the Buddhist Prajñā or Dharma) and the "Divine Man" (Purusha of India), were formed the worlds. This chaos is the *Ungrund*, the great "All" and the great "Nothing" of Boehme. There is no light, no fire, nothing defining and defined, because ground, cause, or basis can only appear when the different, the definite, is made manifest. In this stillness lie the Father, the Son, and the Holy Ghost. Then by the aid of the Seven Spirits, of whom more anon, God created abodes of bliss peopled with the angel cohorts of Uriel, Gabriel, etc. But one of these angel chiefs, Lucifer, revolted, and this is the corner-stone of Boehme's system.

He divides space into what he calls the "Three Principles."

*First Principle.*

The Kingdom of Hell. It is put first.

*Second Principle.*

The Kingdom of God.

*Third Principle.*

The Astral Regions—namely, Earth and the stars.

This is a little quaint, but Boehme wished to indicate the three principles in man's soul, the microcosmos, Humanity with hell and heaven battling for mastery. This is practically the same as the "Three Principles" of the Kabbalah—Spirit, Matter, Union (Franck, *La Kab-*



bale, p. 179). Matter may be called "Hell" by a figure of speech. Boehme, following the Kabbalists and Buddhists, calls it also "Sophia," and "The Mirror," because the mystery of Spirit can only be appreciated by God's seen work. The Kabbalah had seven minor Sephiroth, the Buddhist Pâramitâs, or Attributes. This is Boehme's version of them. He calls them "Angels," also "Spirit-sources."

1. The astringent quality.
2. The quality of sweetness.
3. The quality of bitterness.
4. Heat.
5. Holy love.
6. Sound and tone.
7. Body.

I do not know that this list is better than the Buddhist list. The Pâramitâs are simply the attributes of the Supreme Buddha. The crucial design of Boehme, it must be remembered, was to make each individual mount the occult and mystic ladder:

"The Ladder of Jacob was shown me. By it I mounted up to heaven, and received the goods that I sell. If any one wishes to mount with me, let him take care that he is not drunk. Let him gird himself with the sword of the Spirit, for he must pass a giddy abyss. Through Hell's Kingdom lies the pathway, and through much laughter and mockery. In the fight the heart will fail. I have seen the sun blotted out, but again its light appeared. I speak not my own praise, but to bid you not to despair. For he who, standing between Heaven and Hell, would fight Satan, will get rude blows from a fearful adversary. Let him wear the Armour of God. The way is narrow—through hell's portal. This is a great mystery.

\*            \*            \*            \*            \*

If you wish to enter the Divine Portal, you must walk in the fear of God." (*Morning Redness*, xiii. 20.)

The following eloquent tribute to Boehme is from an American newspaper:—

"In Boehme's formula of the self-existent God—'Nothing,' 'All,' 'Father,' 'Son,' 'Spirit,' 'Word,' and 'Wisdom'—we have the ground of all the speculations of the

past, whether Pagan or Christian, as to the inscrutable, unknowable Absolute. These, too, may be found, in one sense, in the 'Unconditioned' of Kant, Hamilton, Mansel, and Spencer. Boehme declares the one sole Existent Divinity is 'unknowable'—except by apprehension of the highest angel, and then only as mirrored in the Divine Wisdom—the reflection of the 'All' discreted from this self-existent God in the ever-generated 'Ideas' which he calls the 'Unbeginning Beginning'—the 'Eternal Nature.' In this fluidic ocean of Life all the germs of whatever is are manifested. It is the beginning of cause—the beginning of the finite—the beginning of so-called 'creation.' From this starting point each germ is differentiated, containing within itself the potency of its after evolution. All through his writings this thought is dwelt upon; now in abstract statement, now in similitude, and often personified. Is there not here a hint of the now scientifically demonstrated law of evolution?

"It is claimed that Kepler was indebted to Boehme for many of his thoughts and theories in regard to astronomy. It is well known that Newton acknowledged his indebtedness to Boehme for his theory of gravitation. Much that is in chemistry can also be traced to his suggestions. Boehme was a seed-sower, without much method, it is true, in his seed sowing. The fruit of his thought has made the conditions, however, in the mentality of the race by which others could come forth and do a larger work. Without Boehme it is possible no such great thinker as Swedenborg could have come upon the scene and have acted his part. Much that is in that great seer's work can be traced in Boehme's writings. Swedenborg was a scientist, equipped with a university education to start with, and hence was better able to express his thoughts than Boehme.

"Boehme will be a perennial fountain to many minds of a mystical and speculative turn. It is well for those who have the time, the intellectual ability, and the inclination, to study both. No one can ever master Boehme at second hand; one must not only be imbued with his spirit, but must, in a certain sense, become *en rapport* with his state. One must see underneath his jargon, his uncouth way of

presenting mystical truth, an harmonious, systematic, and beautiful theory, clothed in the serious religious garb of the sixteenth century. He claimed the 'Divine Sophia' as his bride; and certainly he was loyal to her behests; for he was a life-long sufferer for his devotion to what he considered truth."

Comparing the work of Swedenborg with that of Boehme we must say that to the former we owe a mighty debt. At one fell swoop he has chased away the army of "astral spirits" and "elementary spirits" that the old world believed in. The ancients in their ignorance thought each star a spirit, and imagined that a swollen torrent that swept away a village was the work of an Undine, and that a conflagration was due to a Salamander. The Kabbalists, in their hole and corner rites, kept alive this delusion. "The Higher Kabbalism (*la Haute Kabbale*)" says Migne's excellent "Dictionary of the Occult Sciences," "sought exclusively to control the spirits of earth, air, fire, and water." Swedenborg has also swept away Boehme's spotless and mindless "angels," who without intestines, and without the ducts and drain-pipes that nature has provided for her chemistry, eat delicious fruits, and sing psalms for ever round the throne of God. Swedenborg announces that all angels are dead men, a fact confirmed by Matthew (xxv. 31) and Jude (ver. 14), one of whom calls Christ's attendants at the second advent *ἅγιοι* (saints), and the other *ἄγγελοι* (angels).

And this good work of Swedenborg has been carried still further by the experimental occultism of to-day. Thanks to it, and notably to Mr. Stainton Moses, we have a picture of the next world which is at least credible. In it we see the same husbandry of means that we see here, the same intelligent use of pain and sorrow. In it we see energy preferred to idleness. We see the gradual advance of the whole through the efforts of the strong in aid of the weak.

But we owe much to Boehme. Swedenborg discouraged all occultism except his own. The bridge that took him to the next world he tried to break down afterwards, and "the Lord" enacted that mankind must see God through Swedenborg's spectacles. Boehme proclaimed

that no one could see God except through the Divine Sophia, the mirror in his own mind. All who neglected this, however accurate the imitation Gothic of their churches, were "Porkers of Satanas," "Dancers on the Narrow Plank," "Epicureans," "Semi-corpses." The Bible was valuable but only when the divine man, the higher Ego within, had taught the reading of it. The mystical "Resurrection of the Dead," must take place in this world. The head of the "serpent," the "Selbheit," the lower self, must be crushed. Then a mortal can eat the mystical bread and wine, that is take into his mouth the atmosphere of the plane of spirit. Then the Father will beget the Logos in the individual heart. Then the Seven Quellgeister will appear there. All this is of immense importance, but upon one point experimental occultism corrects intuitive occultism. Boehme ignored the action of intermediate agents between man and God, especially the good ones. The modern apostles of intuitional occultism instance this as his one conspicuous merit. They cite St. Martin, who, when Lavater was holding *séances* of evocation, wrote to Kirchberger that these were most dangerous and that the "internal teaches everything." Let us see first what Boehme really did announce.

There are three sets of souls saved from hell after death. The first have not yet attained heaven, but "stick in the source quality or pain in the Principle of the birth."

"Many come again with the starry spirit, and walk about in houses and other places, and appear in human form and shape, and desire this and that and often come about their wills and testaments." (*Forty Questions*, Q. xxvi. 12.)

These are interested in children and friends "until the starry spirit is consumed. Then they sink down into their rest." They care no more for earthly things "when they have come to grace."

One thing is plain here, that the "astral spirit" of Boehme is something quite different from the "astral body" and "astral spirit" of Madame Blavatsky. He uses the word "astral" for material.

The second group "sink down in their dying without a body." They appear "magically" to good men in their dreams.

The third group are in the Bosom of Abraham. "These none can stir unless they will themselves." They neither pray for us, nor "take upon them any earthly thing at all." (Q. xxvi.)

A word about all this. Let us take Boehme himself. Was he so completely intuitional?

Let us suppose for a moment that he had been born of brigand parents in Calabria. Would he then by his own unaided inspiration have given hints to philosophers like Hegel and Schelling? Or would he himself have been shot as a brigand? I will go a step further. As a cobbler at Gorlitz, without the aid of Walther and the Kabbalah, it is quite certain that his excursions into the *Ungrund*, would never have got further than the Pastor Primarius and his catechism. Walther taught him the secrets of magic, Eastern and Western. This gave helping spirits a field to work on. They pushed him at last through the mob of "elementaries" and "astral spirits" to the great Beyond.

Were all these spirits good? Experimental occultism has shown us that this can never be so.

"Turn me not into derision. If one should say: 'This madman has never been up into heaven. He has seen neither this nor that. These are fables!' Then by the right I acquire from the divine illumination I will cite you before the judgment. The door will close against you. You will not be able to enter. You will dance with hell's wolves in the infernal abyss." (*Morning Redness*, v. 14.)

All prophets at times think they have a right to talk thus. Modern Psychism throws a light on this, and also on the revelation of Boehme and Swedenborg. Placing ourselves in the position of the guiding spirits we see at once that they can only give what a mortal can take in. With Swedenborg and with Boehme the word "God" meant Jesus Christ; and the minds of both were steeped in the Jewish theology. With both it was sought not to

overthrow but to spiritualise this, to advance from symbol to the fact symbolised. To talk about Christian mysticism, Buddhist mysticism, the mysticism of the Sufi, is to use words without meaning. When we pass the great portal, the yellow sanghati, the cope, the Calvin's gown fall off.

## CHAPTER III.

### 'MADAME GUYON.

EARLY Christianity was pure occultism. It emerged from the disciples of John and from the Essenes, Jewish mystics, who retired to the desert to gain a knowledge of God in the visions of extasia. Renan shows that the first Church of Jerusalem was a conventicle of illuminati. All had miraculous gifts, prophecy, tongues, shiverings, "as in the English or American sects of the Quakers, Jumpers, Shakers, Irvingites." When Christianity spread, the rules of these early churches became Utopian. The lay element was by and by introduced, and the mystics took refuge in the monastery. (*Les Apôtres*, p. 128.)

"All the teaching of the Fathers of the spiritual life like Jean Climaque, Basil, Nil and Arsene, all the secrets of the interior development, one of the most glorious creations of Christianity, were in germ in that strange state of the soul which the illustrious ancestors of all whom St. Martin called *Hommes de désirs* passed through in their months of extatic waiting." (*Ib.* p. 73.) The lay element has now completely swamped the Higher Christianity, although the oyster shell remains. In the reign of Louis XIV. of France the great crisis arrived. Molinos, Fénelon, and Madame Guyon were bitterly persecuted, and interior Christianity was nicknamed "Quietism," and pronounced heretical. All this is so vital to our inquiry that a short sketch of Madame Guyon's life will not be out of place.

Jeanne Bouvier de la Motte was born at Montargis on the 13th April, 1648. She was brought up in an Ursuline convent, and wanted to take the veil. When little over fifteen years of age she was married to a gouty gentle-

man twenty-two years her senior, and furnished at the same time with a real French mother-in-law, acrid, exacting, miserly, impossible to conciliate. M. de la Motte, her father, was a gentleman of position, exercising much hospitality in a luxurious house. In the *Maison de douleurs* of M. Guyon all was changed. The mother-in-law was so avaricious that she scarcely allowed the inmates enough to eat. She soon began to hate and persecute her daughter-in-law, who was very pretty and very much courted by the scented gentlemen in full-bottomed wigs that frequented Montargis. Nothing satisfied her. If Madame Guyon, junior, snubbed these she was said to be *farouche*; if she didn't snub them she was said to be something worse. The young wife admits that she herself at this date had grave faults as well. If she heard another beauty praised, she lost her temper; and she was even guilty at times of going to church less to praise God than to show off her fine dresses. Then came fits of compunction, and she would not allow her maids to *friser* her hair, or to put rouge on her cheeks. But, oddly enough, she was quite as much admired without the rouge as with it.

When the young woman was eighteen she came across a Madame de Charos, who had been instructed in the mysteries of the inner communion by a missionary, who had probably derived some of his knowledge from contact with the Buddhists of Cochin China, whence he had just returned. Madame Guyon heard these two converse together without understanding what they were talking about. What was this "union with God"? What was this ecstatic "contemplation"? She consulted her confessor, and found that he knew as little about it as she did. She practised all the rigours of her Church, used scourges with wire, scourges of thistles. She walked about with gravel in her shoes, and put colocynth in her food to induce nausea and loathing, but the bliss felt by the old saints refused to come. At length day dawned. She was induced to consult a young Franciscan. This monk, although much embarrassed and indeed frightened at having to advise so beautiful a young woman, listened to her story. He then uttered a few words which were



destined in the end, to spiritualise many Wesleys and Kirke Whites:—

“Madame, you are seeking from without that which is to be found within. Seek God in the heart!”

From this moment a new life was hers.

“I was plunged into quite a river of happiness. I know by faith that it was God who possessed my whole soul, but I thought not of it. A bride knows that her husband is by her without saying ‘It is he!’”

But her ecstasies were balanced by the *Maison de douleurs*. M. Guyon, who had the gout, was angry that she neglected her duties as a wife, and his mamma was also quite equal to the occasion. And the old Barnabite confessor, who had been superseded by the Franciscan, got all his brothers to preach in Montargis upon the text of “silly women,” and to talk about “suspicious devotions.” She had become the Bride of Christ.

In the year 1675, M. Guyon died, leaving the young widow the charge of five children. “For twelve years and four months,” she said, “I endured the cross of marriage.”

In France at this period there was a law called *la garde noble*, which gave to the survivor of a married pair of rank the control of the family wealth until the children came of age. Madame Guyon was now very rich, and this unexpected change of fortune plunged her into deeper melancholy. She gloated, she said afterwards, over her wealth and her new position. She foolishly allowed the acrid mother-in-law to remain with her children. But her inner life and her outer life were warring together more desperately than ever. A secret voice kept telling her of her high mission. “Tu es Petrus!” it whispered one day. She was, like Peter, to found a new Church. It was to be the New Jerusalem of the Apocalypse coming down from the skies. This was a singular anticipation of Swedenborg,

And yet this unworthy apostle, instead of thinking of heavenly things, was counting her *Louis d'or* and quarrelling with her cook. The poor woman looked round for advice. There was but one priest in the world who seemed to understand her exact difficulties. This was

the Father La Combe, but he had gone off to Switzerland. He was a mystic himself, and had long encouraged her holy dreams. Should she follow him to Geneva?

At Paris she consulted a Dominican. He advised her to see Bishop Aranthon, who had just come to the French capital to get funds to found at Geneva a nunnery of *Nouvelles Catholiques*. M. Guerrier in his biography of Madame Guyon describes this prelate as being benevolent and gentle (*bon et doux*). The benevolent prelate advised her to repair to his diocese. A great struggle took place in her mind, for she feared her relations. She opened a Bible for a text-divination:

"Fear not, for I the Lord thy God will hold thy right hand." These words from Isaiah met her eye.

Doubts still remained. One day by accident she entered a church and confessed to a priest whom she had never seen before.

"I do not know who you are, madam," he said, "but an inner voice tells me to say to you, Go and do what the Lord Jesus has wished you to do."

This "miracle" clenched matters. She started from Paris with some "daughters of the congregation," with two maids, and with a little girl aged five. Soon they found themselves at Anneci, and the party visited the tomb of St. Francois de Sales, whose mystical writings had much moved Madame Guyon. Before leaving Paris that good lady had signed away nine thousand *livres* at the instigation of the "gentle" bishop. Soon the party arrived at the convent at Gex.

A young widow, fashionable, handsome, and very rich, is courted in the provinces. She was much run after. The "gentle" bishop gave her the Père La Combe for a confessor. The little town of Gex echoed with her liberality. But a strange prophecy came to her which she sent to La Combe.

"The legions of hell will unite to arrest the inner growth, and the formation of the Christ in the souls. The storm will be such that no stone will remain on another. On earth will be trouble, war, and a great overturning. Woman shall be big with child of the inner Spirit, and the Dragon will stand up before her."

Voltaire sneers at this prophecy, knowing nothing about a great overturning. At any rate tangible troubles soon came. Madame Guyon learnt that all France was denouncing the inhuman mother who had deserted her children, and was fooling away their money. And her little child, exposed to the bad fare and want of her old comforts in the convent, soon faded away and appeared about to die.

All this seemed now to her to be due to her folly. She tried to make amends, by signing away her rights to the money of her children. She reserved a small sum alone for the support of herself and her little girl.

But this brought the "gentle" bishop upon the scene. He was very angry at the step she had taken without consulting him. She was soon made to feel the difference in the status of a rich widow and a pauper.

Behind the bishop was a priest named Garrin. This man had fixed his eyes on a very pretty nun that Madame Guyon had brought with her from Paris. He wanted to be her confessor. Madame Guyon had baffled him here. "I would rather see one of my daughters die," she said. She warned the girl of her danger, and persuaded her to confess to Père La Combe, the official *directeur* of the nunnery.

A scheme of petty persecutions was now set on foot. The bishop wanted Madame Guyon to give up all her remaining fortune to the church. He also wanted her to take the veil. Her servants were taken away from her. Servile duties were given to her, such as scrubbing the floor of the chapel and washing linen. The priest Garrin wanted to get her completely in his power, says M. Guerrier. He did not desire that an inmate of his nunnery should go abroad and tell stories. All her letters were stopped, and her small supplies of money. Before, her large remittances were always seized by the superioress.

In despair she went to the convent of the Ursulines at Thonon. There was a real hermit at this place, who lived in a cave, and fed on grain. He was much impressed at the sight of her, and announced that Providence had "great designs" to be effected through her, but that she was destined to encounter "strange crosses."

One of these was the food at Thonon. Owing to the great heat, the meat was putrid and full of maggots. The bishop still pursued her, and ordered the Père La Combe to use his influence, to make her become a nun and give up her property. He refused manfully. For this he was afterwards shut up for life. Madame Guyon, sick and sorrowful, had here a strange vision. She saw the Père La Combe, naked upon a cross, but the populace around hooted her and not him.

In point of fact, she was in modern phraseology a strong medium. At night at Gex there were frightful noises in her chamber, her bed shook, and the "paper sashes" constantly burst. One night she saw the devil. "It seemed a kind of face seen by a blueish light. I don't know whether the flame itself composed that horrible face or appearance."

La Combe was also a strong medium. He was summoned when she was almost at the point of death, and at once she recovered. When he was bearing her and her child away in the passage-boat on the lake, she was oppressed with a cough. "May that cough cease!" he said, and she coughed no more. The two could converse for hours together without opening their lips. At Thonon she composed her two chief works, the *Moyen Court*, and in 1683 the *Torrents*. With their composition she affirmed that she had nothing to do. She was strongly impelled to take up the pen. "Before, I wrote I knew nothing of what I was going to write, after I had written I remembered nothing of what I had penned." In fact the little works were written "automatically," in the language of modern spiritualists.

She now went to Turin, and then to Grenoble, to Marseilles, Alessandria, and Verceil, everywhere pursued by the persecutions of the bishop. After a five years' absence she returned to Paris.

But now a more formidable enemy appeared in the field, the Père de la Motte, her own brother.

This gentleman had wanted a greater share when she handed over her *garde noble* money to her relations. Also, although she gave him a portion of her little annuity, he thought that portion was not enough. Then the Père La

Combe had arrived in Paris at the same time as Madame Guyon, and the Père La Combe drew crowds to his eloquent sermons, whilst those of the Père de la Motte were dull and commonplace. Jealous of a brother Barnabite (they were both of the same Order), the Père de la Motte schemed to ruin his "brother," and also his sister. He sent an "agent," a Madame Gauthier, to confess before the Père La Combe, and she reported Molinism in his teachings, although the heresy, it was affirmed, was extracted from the condemned works of Molinos, and was never uttered by the Father at all. He was thrown into prison without any serious attempt at investigation, and kept there for life. Also, by order of the king, Madame Guyon was arrested on a charge of Quietism.

What was Quietism? What was Molinism? An answer to these questions will carry us back a long way.

The early stone-using man many thousand years ago conceived an unseen Being. Like the Tsui Goab of the modern Australians, his first god was an ancestor. And as the ancestor in life loved human flesh, bull's flesh, a superior wigwam, much flattery and much homage, religion began to consist of meat-offerings and drink-offerings, a palace for the god and an elaborate system of court ceremonial.

But by-and-by, on the banks of the Ganges, a great advance was made. It was judged that instead of trying to conceive god from the externals of humanity, it would be more wise to look for hints of him into man's soul. And as some men seemed more spiritual than others, and as this state of spirituality seemed to advance as the entanglements of the lower life diminished, it began to be judged that by deadening or "mortifying" the flesh the spirit would become lucid. Hence Yoga in India, and the Eremites (from Erema, the desert) in Christianity.

As early as the date of the Atharva Veda, or say roughly a thousand years before Christ, the Rishi Angiras informed the wealthy householder, Saunaka, that there were two sorts of knowledge—the "superior knowledge" and the "inferior knowledge."

"Know Brahma alone!" was the motto of the superior knowledge.

An extract from the *Mundaka Upanishad* of the Atharva Veda may here throw light on Brahma and union with him:—

“He is great and incomprehensible by the senses, and consequently his nature is beyond human conception. He, though more subtle than vacuum itself, shines in various ways. From those who do not know him he is at a greater distance than the limits of space, and to those who acquire a knowledge of him he is near. Whilst residing in animate creatures he is perceived, although obscurely, by those who apply their thoughts to him. He is not perceptible by the human sight, nor is he describable by means of speech, neither can he be the object of any of the organs of sense, nor can he be conceived by the help of austerities and religious rites. But one whose mind is purified by the light of true knowledge, through incessant contemplation, perceives him, the most pure God. Such is the invisible Supreme Being. He should be seen in the heart wherein breath, consisting of five species, rests. The mind being perfectly freed from impurity, God, who spreads over the mind and all the senses, imparts a knowledge of Himself to the heart.”

The mystics of all lands sought this union by extasia, by contemplation. Yoga, the word for Indian magic, means simply “union.” Sangha, the third person of the Buddhist Trinity, also means “union.” The divine man, Parusha was the result of an union between Buddha, spirit, and Dharma, matter. Thomas à Kempis, in his *Soliloquy of the Soul*, has a chapter headed “On the Union of the Soul with God” (chap. xiii.). St. Theresa had her *Oraison d'union*. St. Augustine based all his mysticism on the text (John xiv. 23): “Jesus answered and said unto him, If a man love Me, he will keep My words: and My Father will love him, and We will come unto him and make Our abode with him.” Clement of Alexandria sketches the scheme of the “Christian Gnostic”: “Dwelling with the Lord He will continue his familiar friend, sharing the same hearth according to the Spirit.” (*Misc.*, p. 60.) Ignatius Loyola drew up certain spiritual exercises.

What was the object of these spiritual exercises?

Extasia, the divine vision, the Indian Dhyani, what the Catholics call "contemplation." It is defined by Ignatius Loyola as "the application of the five senses of the imagination."

After an elaborate preparation, consisting of a prolonged examination of his soul and his past life, by the novice, after a general confession and a receiving of the Holy Communion, after a proper use of "hair-shirts," "fastings," the "discipline, or scourge," the novice, left alone in his solitary little cell, is told to try and conjure up in his mind some given scene from Scripture, say the birth of Christ.

"The pupil must with the eyes of his imagination see Joseph, Mary, and the stable of Bethlehem. Then he must hear by the help of the imagination what the holy actors say to each other." Scene after scene is given for contemplation—the Presentation in the Temple, the Crucifixion, and so on. The novice has even to try and conjure up a somewhat material vision of the Trinity. And he must make hell so real that he can actually smell the sulphur and hear the cries of the damned.

"Know holy wisdom to be the same as yoga," says Yajnyavalkya. "That which is termed yōga is the union of the living with the Supreme Soul." To attain this result in India the five states of yama must be mastered. The Indian yoga is so very like this Catholic contemplation that, assisted by Wilson the Orientalist (*Vishnu Purāna*, p 652), we will give a sketch of it.

After a long fast and purifications, the Chela, or novice comes with an offering of flowers, sesamum, rice, kusa grass, etc., into the presence of his guru or teacher. A patron saint is selected, as with the Roman Catholics, and a burnt offering is presented to this saint by the guru. The guru then whispers thrice in the right ear of the novice the Vija mantra (incantation). It is a monosyllable with the initial consonant of the name of the deva, and a final "a" or "oo." Thus Kṛiṣhṇa would be "Kra" or "Kroo."

From this moment the chela must look upon his guru as a sort of incarnation of the deva. He must treat him like an idol on its shrine. He must worship his feet, and

present to him the sweetmeats and clothes and flowers and fruit that are presented to Krishna. When he washes his master's feet he must drink some of the water. This superstition is not altogether confined to the East. In French novels when the priest speaks as a priest, the hearer accepts his utterance as the voice of God, "*C'est Dieu qui parle!*"

The novice now squats down cross-legged in the conventional attitude of the figures of Buddha. He tries to arrest his breathing. This is the great secret of Indian magic. He must with his fingers and thumbs prevent all air from issuing from mouth, nose, etc. Sometimes a large piece of cloth is rammed down the throat, and kept there as long as possible to assist this. In his dreamy reverie the novice has much the same task given to him as the Catholic novice. He must first try and conjure up the anthropomorphic God, Hari, "with smooth cheeks and a broad, brilliant forehead," Hari with four arms and with splendid earrings, Hari with a painted neck and with the "Srivatsa," a sort of St. Andrew's cross, on his breast; Hari with a "belly falling in graceful folds"; Hari with the mystic shell, mace, quoit, and bow. But after a time he is enjoined to discard this anthropomorphism, and to meditate upon the mystic symbols alone. We see at once here a great superiority over Ignatius Loyola's system. He strives with the "five senses of the imagination" to what we should now call "materialise" the anthropomorphic God. The Indian mysticism tries to get rid of him. This four-armed God from the very first is plainly a symbol, made use of to get up by and bye to the formless, ineffable Brahma.



Called by Am  
Ed Bonetti Miller Son  
6/1-A, Wash. Ave. Quebec Lane  
Calicut - 70000  
NOT EXCHANGEABLE AND  
NOT SALABLE.

## CHAPTER IV.

### *MADAME GUYON (Continued).*

IN the year 1528, there was a prisoner in a dungeon at Alcala, in Spain, accused of being connected with the Alombrados or Illuminati. This prisoner was Ignatius Loyola, the founder of the Order of Jesus.

Who were the Alombrados? and had Loyola anything to do with them?

These are questions that cannot be answered with much certainty now. The Alombrados seem to have been a secret society of mystics, something like the Sufis. When Islam attacked Western Persia, and tried to drive the Buddhists there into the fold, a curious result took place. The Buddhists made half of Islam Sufis. These secret societies, under the name of Ismaelites, spread rapidly. They had many severe rites of initiation, the earliest on the surface teaching orthodox Islamism. They proclaimed the Seven Great Imams, seven successive incarnations of the Supreme in mortal shape. This is plainly the Buddhist doctrine of the Seven Mortal Buddhas. In the last stage of his initiation, the inquirer was told that there was no God. This is the accusation of orthodox Islam. But more friendly critics affirm that the God proclaimed was the God of Indian pantheism. It was proclaimed also that the laws of religion and morality were of human manufacture.

During the rule of ignorant violence secret societies are the only weapons of the more intelligent. But unfortunately in the process of time some of these Ismaelites resorted to violence in their turn. The Hashishin arose, the celebrated "Assassins" of our crusaders, although Mons. Silvestre de Sacy has proved that the term is derived from hashish, the Eastern intoxicant.

Von Hammer, in his *History of the Assassins*, p. 216, asserts that the Jesuits, without doubt, "trod in the footsteps" of these Hashishin or "assassins." The analogy between them is sufficiently close.

1. Both societies had many degrees of severe initiation, a master, companions, novices, etc.

2. Both used assassination to terrorise and dominate Caliphs, kings, ministers, and other influential persons.

3. Both trained young men to a rigid obedience, and promised them exquisite bliss in the next world if they used the dagger whenever ordered.

4. Both sought to procure for the chief or general of the order universal dominion, using religion as a cloak.

6. The Hashishin in the last degree of initiation taught blank atheism, and pronounced morality to be merely expediency. The same is said everywhere of the Jesuits, and judging by history the charge seems just.

The Hashishin, as a political body, disappeared from the page of history a little after the crusades. But as a secret society of mystics they continued to be active, and they still exist. The Berbers, or natives of Barbary, were deeply impregnated with their doctrines, and these Berbers overran Spain. Thus Loyola may have come under their influence. Of all Christian kingdoms, Spain has been most prone to mysticism.

The dream of Loyola by and by became concrete. His army of "Black Cloaks" worked hard to obtain universal dominion. They established missions in the West, and also in the East. They started colleges everywhere to get the rising generation in their power. They schemed to give Jesuits as father confessors to every king, every powerful statesman, every fine gentleman, every scheming lady. They spurred religious enthusiasts, but made things easy for fashionable penitents. Religion and morals were used as counters in the game. Man has at times noble aspirations. These they fanned. Man has at times ignoble aspirations. These they fanned also. The Ismaelites were started to oppose a dominant superstition. The Black Cloaks saw at once that it would be far more politic to use a dominant superstition.

The first efforts of the Black Cloaks were to gain Spain.

But as that kingdom deteriorated, they fixed their eyes on France. Their "great aim," as they called it, was to make the French king a figure head, and rule through his confessor. With vast ability this plan was carried out. The power of the Emperor of Germany, and of the King of Spain, was gradually broken. The Huguenots were exterminated, and the power of the French nobility reduced to insignificance. Under Louis Quatorze the French arms were everywhere successful. The king dominated Europe, and behind the king was a Jesuit. Let us listen to the Duc de St. Simon.

"When Father de la Chaise found himself dying, from his death-bed he desired the king to take another member of his Order as confessor, warning him that if he did not do so, he ran the greatest risk of being assassinated by the Jesuits, who had not scrupled to kill his great ancestor, Henry IV.

"Louis XIV., not braver than his distinguished progenitor, dared not refuse, even had he wished so to do. The Jesuit Order fixed upon Father Le Tellier, then Provincial of Paris, as the member of their Society fittest for the post" (*Memoires*, vol. iv. 285).

This passage lets in a great deal of light. It is plain that the Western Hashishin worked quite as much by the bold menace of the dagger as by its actual employment. Evidently this could not have been the first conversation that the king and his father confessor had had on the subject. The Duc de St. Simon himself was nearly frightened out of his wits at some very plain words which Le Tellier spoke to him one day. Five or six times the life of Queen Elizabeth was attempted. Five or six times the Jesuits tried to kill James I. Armand Carrel gives very strong facts, which lead to prove that our Charles I. was poisoned by them. The Duc de St. Simon shows that the Duc de Bourgogne, the heir of France, met with the same fate, because he sided with the Gallican Church. More than one pope is said to have perished at their hands.

Thus France was a huge reign of terror. A little bald gentleman in a full-bottomed wig and high-heeled shoes strutted about Versailles with pretty manners, and

behind him was murder and the terrible Bastille. This much-bewigged little gentleman was quite absolute. All the emoluments of the state, the army, the church, were in the hands of his mistresses and his confessor. The vaguest charge of heresy or disaffection might consign anybody to a filthy dungeon for life. The Jesuits attacked everybody to bring about one dead level of servility. They waged a long and fierce war with the Gallican Church, and persuaded the king that Jansenism meant civil rebellion. Of more immediate interest to us is the fact that they waged war against Quietism.

A priest named Michael Molinos published, in 1675, a little book called *The Spiritual Guide*. Molinos was a Spaniard. He belonged to the country where Santa Theresa and St. John of the Cross founded the Carmelites. He was an ardent mystic, and at first the Pope of Rome and Louis XIV. much approved his teaching.

But by-and-by the Jesuits took up the question, and forced Louis to throw the weight of his influence into the controversy. Molinos was arrested in Rome, in 1685. On the 28th August, 1687, sixty-eight propositions of his little book were condemned, in a decree that alluded to him as the "Son of Perdition." This judgment was confirmed by Innocent XI. Molinos was locked up, and died in prison.

Molinos has recently been made the hero of a popular modern novel. What was "Quietism"? and how was it that he came to be looked upon as the Son of Perdition? In Migne's *Dictionnaire d'Ascétisme* we can see how Catholic doctors view the subject.

The object of the Quietist is to annihilate the Ego, and to become united with God. Perfect contemplation, according to Molinos, is a state in which the soul does not reason. It reflects neither on God nor on itself, but in a passive state receives celestial light. It is held that this divine dreaming encloses in itself all the acts of religion and that a soul which has reached this state cannot lapse except by an express act of the will. In this state there is no desire of heaven nor fear of hell, but perfect indifference. And the orthodox doctors of the Church add that these mystics even consider the "sacraments of the Church" unnecessary; and also, the "practice of good works."

Now, without stopping to consider how much of this was really preached by Molinos, and how much is inference, we may say at once that we have here the antagonism of two distinct religions, the higher Christianity and the lower. The order of Jesus made an end of Molinos without any doubt, but it may be questioned whether they did not also make an end of the religion of St. Paul, St. John, St. Clement of Alexandria, and the long line of Catholic Saints.

“Thou shalt love the Lord thy God with all thy heart, and with all thy soul, and with all thy mind. This is the first and great commandment.”

But if the saint in his extasia was obliged to keep in view that the divine object of his heavenly rapture had foreordained at least nine hundred and ninety-nine souls in a thousand to eternal torture, and that in consequence his own chance of escape was arithmetically small, obedience to this commandment would be practically impossible. Old travellers in India describe a very beautiful female Thug, whose smile was sought by many ardent young Hindoos, but if one of these had been told that the embrace that he so much desired would be with the terrible roomal his love could not have remained at fever heat. The higher Christianity was, as we have seen, an attempt to bridge the world of matter and the world of spirit, and to form a worthy idea of God by sublimating the mind of the individual. The religion of the Jesuits, the religion of Sacraments, was simply state ceremonial. They could tell what was to be done with rosaries and with the ointment of the Sainte Ampoule, but all this in its ultimate had nothing to do with religion at all. Nor had it much to do with morality, as *Porte Royale* significantly urged. The morality of the Jesuits was attention to the Sacraments and general licence (*Mémoires de Porte Royale*, Vol. 1, p. 520).

Madame Guyon remained in prison eight months. The Archbishop of Paris, M. de Harlay de Chanvalon, conducted the inquiry with much acerbity. According to Voltaire the wits drew attention to the paradoxical fact that a gentleman who was too soft to most women (*Connu pour aimer trop les femmes*) should persecute one who

spoke of nothing except the love of God. It was this gallant ecclesiastic that got a *lettre de cachet* to confine the Père La Combe in the Bastille.

But even in the best regulated despotism there are wheels within wheels. Madame Guyon had a cousin, Madame de Maisonfort, in the Maison de St. Cyr, a convent just now in the course of formation. This lady was a favourite of the king's left-handed wife, Madame de Maintenon. Madame Guyon had also for friends the Duchesse de Chevreuse, and the Duchesse de Beauvilliers. These persuaded Madame de Maintenon to interest herself in the poor persecuted lady. This was enough for the courtier Archbishop. He released Madame Guyon.

Meantime her fame had been spread by this persecution, and her writings began to be admired. On her release from prison she went to the Convent of St. Cyr. There, says Voltaire, "she assisted at some pious 'conferences,' conducted by the Abbé Fénelon, having previously dined alone with Madame de Maintenon." The word *conferences* in French may mean a lecture where one speaks, or a meeting where more than one holds forth. This was an important distinction in the palmy days of the Bourbons. For any one not a Roman Catholic ecclesiastic to hold forth on religion to a meeting was considered almost high treason. You might as well boldly proclaim the confession of faith of the Huguenots. Madame Guyon found it necessary to record that she never in her life addressed even three people at a time on religious subjects.

It was here that commenced the friendship of this lady and Fénelon. He had read her two little volumes, and they helped to develop his own interior knowledge, for he was a born psychic. She called him her son. When the two were subsequently in disgrace it is said that they could converse together, even through the grim stone walls of the Bastille.

Fénelon is the most lovable priest in the Gallican church. He was a perfect gentleman, conscientious, eloquent, dreamy. When sent by Louis to Poitou to convert the Huguenots he refused the help of the terrible "Dragoons." When called upon to teach the little Duke of Burgundy the heir of the French crown, with unsophisticated zea

he sketched in his *Télémaque* an ideal prince who contemned tinsel show and lavish expenditure, preferring happy and prosperous subjects to the glory and bankruptcy of many wars. Benevolent and self-contained, Fénelon viewed with hostility not one single human being, but it does not follow that no human beings were hostile to him.

• Two such there were.

The first was the king. He had not yet read *Télémaque*. If a malignant fiend had wished to inspire in a mortal brain the most scathing of satires on such a king, he could have invented nothing more cruel than this little child-story. When Louis read it he danced with agony, and found some satisfaction in tearing with his royal hands the MSS. that Fénelon had left in the palace for the edification of the little Duke. At present his grief was a different one.

In the year 1665, Louis, who had the Bourbon animalism strongly developed, was in difficulties. Amongst the ladies of honour of his wife's court was a lady with whom he had a love affair of the Bourbon type, though more durable than the many others which had already come within his experience. Such an affair, like an attack of typhoid, seems to run a prescribed course. At first, raptures, illusion, a gentle being, witty without malice, loving and beautiful. But by-and-by this gentle being gives place to an ill-tempered French woman in a false position, storming, scolding, disappointed, a woman demanding royal marks of honour for herself, and her too numerous and too healthy offspring. In these difficulties the king turned to a governess of these children for comfort and advice. This was Madame Scarron, a lady who was born in a jail, had been a Huguenot, but was now a Roman Catholic pietist.

The situation was a delicate one. The king was very superstitious. He confided to Madame Scarron on different days his many vows of amendment and his many lapses, Bourbon type. Soon it was a terrible rivalry between two Frenchwomen, for the most pious in those days thought the caresses of the son of St. Louis the greatest boon that Heaven could bestow. When suddenly between Madame de Montespan and Madame de Maintenon came

a third lady, who snatched the prize from both. This was Madame de Fontanges; but she did not long survive.

Madame de Maintenon triumphed at last, and she had the shrewdness to shun royal privileges, four life guardsmen to help her into her carriage, and other ostentations that pleased Madame de Montespan. Also perceiving that the king had two dominant ideas, servility to his passions and his priests, she strove to harmonise the antagonism of these by a private marriage. It is said that Mons. de Harlay de Chanvalon performed this in the presence of the Père de la Chaise.

But by-and-by her ambitions grew, and she wanted to be proclaimed Queen of France. The Père la Chaise, consulted, with a little of the wisdom of the serpent handed over to Fénelon the decision of this delicate matter. He threw himself at the feet of the king, and urged him to avoid so great a scandal. This, according to Voltaire, was the secret of his subsequent persecutions.

The second enemy of Fénelon was an ecclesiastic who had usurped the functions of gentleman usher to royal personages at the gate of paradise. Bossuet, Bishop of Meaux, had been the teacher of Fénelon, and professed now to be his great friend. We all know the *Oraisons Funèbres*. Are they not written in the books of the "*Beautés de la langue Française*." We all know his characters of Cromwell, and of our "glorious," "wise," and "just" Charles II. We all know how, after "nine voyages across the channel in despite of the tempests, Ocean itself was astounded" to see Queen Henrietta of England come once more. We all remember how this good priest, in tracing the lineage of Henriette-Anne of England, was quite dazzled with the transcendent glory (ébloui de l'éclat) of many august crowns. We remember that Virtue was an "immortal mediatrix" between Louis XIV. and Charles II., both men of "noble inclinations."

"Nothing under the sun can be seen equal in grandeur" to the French Royal Family. "The crown of France is as far above all other crowns in the world, as the dignity of royalty o'ertops the baseborn slave." 'Tis thus that a



minister of heaven talks of a mumbling old royal profligate, who desired to turn the group of ladies in waiting on his queen into a nunnery on Monday, a harem on Tuesday, and armed with scourge and rosary penitently wished on Wednesday to change them to a nunnery once more.

Bossuet, the court preacher, had become very jealous of Fénelon. Folks, tired of the artificial insincerities of the former, detected in the latter a genuine man. Madame Guyon was soon again exposed to the persecutions of her enemies. Fénelon gave what seemed to be sound advice. This was that she should place herself in the hands of Bossuet, as the leading authority in France in matters of theology, and accept his decision without reserve.

A commission was appointed by the king to examine her writings. It consisted of Bossuet, the Abbé Tronson, and the Bishop of Chalons. Her works were condemned; and she promised never again to "dogmatise"—a vague word, differently interpreted. In the mind of the king it probably meant preaching like the Huguenots. We have seen that she maintains that she never addressed an audience of over three people in her life. At any rate the charge of "dogmatising" was soon revived, and the king had her confined in the Chateau de Vincennes.

Bossuet, a little treacherously, urged Fénelon to join in this condemnation. He refused. And, indirectly to shield Madame Guyon, he published a little book entitled "The Maxims of the Saints."

Bossuet danced for joy. Eagerly he perused the works of Molinos, and the "decree" that the Jesuits had forced the Pope to pronounce against them. He compared these with the "Maxims of the Saints." Soon he detected "quietism." As Voltaire justly says: "Nothing is more easy, in these delicate matters, than to find in the book you judge passages rather like some in a condemned book." Bossuet threw himself at the feet of Louis, and asked pardon for not having told him before of the "fatal heresy" of Monsieur de Cambrai.

The higher Catholic saints desired to see God by clearing the mental telescope. Voltaire calls this "galimatias."

"Je me connais fort peu en telles matières!" said

Bossuet, "telles matières" being a very good ecclesiastical equivalent for "galimatias." And yet the Bishop of Meaux in his pulpit had contrasted most unfavourably a king (Louis XI.) and his earthly dreams with a monk (St. François de Paule) and his heavenly dreams. Also he had gone into ecstasies at the spectacle of a royal saint (our Queen Henrietta) going for a time into a convent and reading the "Imitation of Christ" to gain complete communion with God. What is the one lesson of the "Imitation of Christ" by Thomas à Kempis?

"The kingdom of God is within you, saith the Lord.

"All His glory and beauty is from within, and there He delighteth Himself.

"The inward man He often visiteth, and hath with him sweet discourses, pleasant solace, much peace, familiarity exceeding wonderful.

"Oh faithful soul, make ready thy heart for this Bridegroom, that He may vouchsafe to come unto thee and dwell within thee.

"The saints and friends of Christ served the Lord in hunger and thirst, in cold and nakedness, in watchings and fastings. Oh, how strict and self-renouncing a life led those holy fathers in the wilderness.

"When Jesus speaks not inwardly to us all other comfort is nothing worth. What can the world profit thee without Jesus?

"To be without Jesus is a grievous hell. To be with Jesus a sweet paradise.

"For the kingdom of God is peace and joy in the Holy Ghost."

Is all this written by Madame Guyon or by St. Thomas à Kempis? It is very difficult to see much difference between the "quietism" of one and the "Bridegroom" of the other, who comes with "sweet discourses," "pleasant familiarity," and gives "peace and joy." Was St. Thomas à Kempis always thinking of the flames of hell? Did he never for a moment forget Friar Tuck and his unguents and holy water? A clever French novelist, Mons. Cherbuliez, lately pictured a modern Catholic bishop of the pattern of Fénelon. He preaches a sermon on what St. Thomas à Kempis calls the interior man. He

announces that Catholicity has always divided mankind into three great groups. 1. Sinners—those who are enchained by pure animalism; 2. The Just, those of the laity who lead clean lives. But it has always steadily proclaimed that heaven can only be reached at a bound by class number 3, those that have given up gold and marriage, the Brides of Christ and the Sons of Wisdom, those who have already passed the mystical portal. Saints on earth as well as saints in heaven.

With an ambitious priest, backed by a king who has the ear of the Vatican, it is not easy to cope. A great paper war arose, for the calmer spirits of the French Church saw how much was at stake. But of course there could be only one issue. Bossuet obtained from the Pope a condemnation of the "Maxims of the Saints." The harmless little book was burnt in the market-place of Cambrai. The sardonic M. Arouet de Voltaire points out a quaint divided duty that the Vatican at this time was called upon to perform. In France it had to incarcerate Madame Guyon, and to force Fénelon to abjure his "fatal heresy." But it was called upon at the same moment by the Church of Spain to canonise Marie d'Agréda, "who had more visions and revelations than all the other mystics put together."

The attack of Bossuet on Fénelon was unfortunate for Madame Guyon, and unfortunate for the Père la Combe, for it was easiest to hit the archbishop through them. Passages were added to her writings and to his. A mock confession on the part of the poor monk, that he had encouraged the lady in dangerous and impure reveries, was forged. When you have got two unbefriended individuals shut up in damp dungeons, it looks as if you could do anything.

But this proved in the end a little erroneous. The spectacle of the gentle archbishop forced to adjure his errors in his own cathedral moved all to pity. And soon the woes of Madame Guyon began to sound all over Europe, and her works to be perused eagerly. Then *Télémaque* appeared, against the will of the archbishop; and being treated as a covert attack on Louis, its success was enormous. The king was terribly angry, and tried

to suppress it in France—a sure way of finding many readers for it. Everywhere Fénelon was adored. Louis had attempted to “dragoon” the Protestants out of France, and indeed out of Europe. But by-and-by these Protestants came back to France, chasing the “dragoons” before them. And their general Marlborough paid a great compliment to the gentle archbishop. His troops were ordered to religiously respect his property.

In the prison of Vincennes, Madame Guyon wrote some verses, “*plus mauvais encore que son prose*,” says M. Voltaire, and he compares them to the love verses of operas.

“L’amour pur et parfait va plus loin qu’on ne pense,  
On ne sait pas lorsqu’il commence  
Tout ce qu’ils doit coûter un jour,  
Mon cœur n’aurait connu Vincennes ni souffrance  
S’il n’eût connu le pur amour.”

This is all very well, but Madame Guyon also might have found some poetry not much better than the love verses of the opera without going much further than the *Henriade*.

“L’amour dans tous ces lieux fait sentir son pouvoir  
Tout y paraît changé. Tous les cœurs y soupirent,  
Tous sont empoisonnés du charme qu’ils respirent,  
Tout y parle d’amour. Les oiseaux dans les champs  
Redoublent leurs baisers, leurs caresses, leurs chants, etc.”

Cowper and Kirke White formed a different estimate of Madame Guyon’s poems, for they both translated them. Here is a specimen by Cowper:—

“By Thy command where’er I stray  
Sorrow attends me all the way,  
A never-failing friend;  
And if my sufferings may augment  
Thy praise, behold me well content,  
Let Sorrow still attend.”

“It costs me no regret that she  
Who followed Christ should follow me,  
And though where’er she goes  
Thorns spring spontaneous at her feet,  
I love her, and extract a sweet  
For all my bitter woes.

"Thy choice and mine must be the same,  
 Inspirer of that holy flame  
 That must forever blaze;  
 To take the cross and follow Thee  
 Where Love and Duty lead shall be  
 My portion and my praise."

This style of religious poetry is not very fashionable nowadays, but at any rate the words have here a meaning. The "cross" with Madame Guyon was more than a figure of speech. In the Bastille and at Vincennes the harshest treatment was for years applied to her.

From the point of view of modern psychic knowledge the chief blot of this Catholic mysticism, as it seems to me, is that it confuses two distinct human experiences. Humanity at its highest, the Buddha, the Spinoza, the St. Paul, by purifying the soul has reached grand hints of God. Humanity also, by known processes, has been able to bridge this world and the spirit world, and to hear the voices of spirits good and bad.

Madame Guyon plainly confused these two ideas. All the voices that were distinctly bad she called "demons." All that were not distinctly bad she called "Jesus." It was Jesus in person that told her for the sake of discipline to lick up the filthy saliva that she saw in the streets. It was Jesus that came to her couch as a Bridegroom. It was Jesus that prompted her no longer to pray to the saints, for of course the "mistress of the house" cannot address her "*domestiques*." Bossuet made a coarse joke about this marriage with the Child Jesus. Another French bishop wrote what might almost be called an episcopal lampoon. One couplet will be enough—

"Par l'époux quelque foi une jeune mystique  
 Entend un autre époux que celui du Cantique."

All this is very well, but these good bishops should tell us who it was that taught young girls to save their souls by becoming each the Bride of Christ. Also who placed the "Cantique," a very erotic Jewish poem, in the hands of these same young girls as a book of devotion.

"Let him kiss me with the kisses of his mouth!"

Madame Guyon, no doubt, runs riot over this passage, and the bishop triumphs easily over her. But the student of modern psychism, who knows all about the incubi and succubi of mediæval convents, must reprove the teacher far more than his unsophisticated pupil. All this business about the "Bridegroom" is very, very objectionable.

And the Catholic Church, by driving out quietism, has driven out all that was vital. There was a dead branch and a living stem. They have cut away the living stem.

## CHAPTER V.

### *THE ILLUMINATI.*

WHO were the Illuminati? Fiction has answered this question very freely. We all know how Wilhelm Meister's apprenticeship came about, under the influence of the mysterious Abbé, and Jarno, and the other members of the Secret Tribunal. In more than one novel of the great Alexander we have found depicted a mysterious being, thwarting the plots of the Court of France by the aid of his occult knowledge, and guiding the great French revolution from his concealment in the sanctum of the Jacobin club. And in the bright pages of Madame Dudevant can we forget the secret crypt in the territories of the mysterious "Prince" in Germany. Thither, at the twelfth stroke of midnight, the novice, hooded, was hurried. And the hood being lifted he found himself in the presence of the "Council of the Invisibles," the terrible "Seven," wearing red cloaks and white corpse-like masks. This subterranean gothic chamber resembled at once a chapel and a tomb. Lights on its walls arranged in the form of a cross made the drawn swords of the masked conspirators glisten with menace. And then their mighty scheme was revealed to him. Civilisation in modern Europe had reached a stage of corruption when any change would be a change for the better. Kings, crowned to protect the weak against the strong, everywhere protected the strong against the weak. Priests, instead of propping up morality, everywhere betrayed it. The intelligence and honesty of the world were banded together to bring about a mighty revolution, beginning in Germany or France. Their motto was "Liberty," "Equality," and "Fraternity." The novice was solemnly offered a place in the

ranks, but was told that it meant vast danger as well as great honour.

And if we turn from fiction to sober history we get much the same story. Louis Blanc is at one with the Abbé Barruel and that fine old Scotch Tory, Professor Robison, on the influence of Freemasonry in those stirring times.

The Baron d'Haugwitz, at the Congress of Verona, used these words: "I acquired then a firm conviction that the drama which commenced in 1788 and 1789, the French Revolution, the regicide, and all its horrors, had not only been resolved in the lodges of the Illuminati, but was due to the association and oaths of the Freemasons."

The Abbé Barruel is more emphatic still. In the year 1798 he wrote a book, entitled, "Mémoires pour servir à l'Histoire du Jacobinisme." In this he affirms that some fifty years before the outbreak of the French Revolution, the Freemasons had organised a vast conspiracy of kings, ministers of state, philosophers, Voltairiens, poets, journalists, mystics, Cagliostros—with a very numerous rank and file. This conspiracy had two main teachings:—

1. All men are equal.
2. All men have the right of freedom.

But this teaching, reduced to its ultimate, meant the overthrow of every government in Europe. The Abbé, writing in England, says distinctly that English Masons will scout what he affirms; but there is an inside and an outside Freemasonry, and he cites the letters of "Philo" to "Sparticus" (classic nick-names were common amongst the Illuminati), which make fun of English "Senior Wardens" and "Worshipful Grand Masters," coming abroad covered with "jewels" and "plumb rules," and being entirely ignorant of what this all meant. The Abbé writes as the initiate of a French Lodge. He tells us that outside Masonry is a farce, a mere parading of recruits to settle which may be hereafter useful. Of course the kings and nobles are not told that the object of the society is to take from them their crowns and privileges. The Abbé gives a quaint list of these initiates: Frederick the Great, Catharine of Russia, the Emperor



Joseph II., Gustavus, III. of Sweden, the Landgrave of Hesse Cassel, Louis Eugène of Wirtemberg, the Princess of Anhalt, the Margrave of Bareith, etc. But even in outside Masonry there is the real secret for those who can read it. A king and a cobbler, a grand-duke and a footman, may find themselves hob a nob in a Lodge, and be told that all are brothers. When upon August 12th, 1792, it was officially announced that France would for the future reckon her years from the birth of "Equality" and "Fraternity," the Freemasons danced with joy:—

"See, now," they shouted, "France is one large Lodge!"

No doubt the good ecclesiastic has a tendency in his writings to confuse "*Dieu*" and the Bourbons. But he writes with knowledge. In the great crash of thrones and churches, frightened Masons, he says, were ready to chatter, especially to one partially initiated. He cites Condorcet as tracing Freemasonry to Manicheism, a heresy attributed to one, Mani—a personage not much believed in by modern scholarship. The most sacred symbol of Buddhism is the *māni*, and manicheism by the early Bulls of the Church was credited to *Bōddā* (Buddha), and *Σκυθιανός*, which last word Weber translates *Sakya*.

A secret society is the corollary to the arbitrary rule of Bourbon and Jesuit, of Sultan and Ulema. When Buddhism reached Western Persia it had to work underground. Hence the Mithraists, the Essenes, the Neo Pythagoreans, the early Christians, secret societies which have had for descendants Sufis, Ismaelites, Templars, Albigenses, Hussites, Kabbalists, Martinists. The Masonic legend, as we all know, records that Hiram Abiff, the builder of Solomon's Temple, met his death at the hands of three fellow Craft Masons, who wished to make him disclose the "word" of the Master Mason. He fled to the east, west, and south doors of the Temple, and then succumbed. The Abbé traces modern Masonry to the Templars. He shows at some length that its rites are a servile copy of their rites. When the order was suppressed the knights dispersed and carried their secrets to Scotland, together with the mystic stone from the Temple of Jerusalem, that was inscribed with the "ineffable name."

Jacques Molay is Hiram, and the three assassins from whom it is the crucial duty of the Mason to exact a huge revenge are king, priest, and soldier. The cable tow is the emblem of slavery round the neck of Europe.

This suggests a pregnant question: were these Aufklärer, these Illuminati, real mystics? In other words, Did the great French Revolution proceed from the world of ghosts?

This is a very difficult question to settle at this distance of time. French books describe two groups of Freemasons. There is the ordinary masonry, and La Maçonnerie Occulte, and the great movement absorbed apparently both groups in its ranks; and the excesses in Paris of the terrible Tribunes made many early partisans anxious to suppress the facts of the past. Gorres was not the only occultist who began as a reforming John the Baptist, and ended in the bosom of the Holy Church.

A passage from Saint Martin, the correspondent of Kirchberger, may be cited here. "Nevertheless, as I believe I speak to a man of moderation, calm and discreet, I will not withhold from you that in the school through which I passed more than twenty-five years ago, spirit communications of all kinds were numerous and frequent, in which I had my share like many others; and that, in this share every sign of the Repairer was present. Now you know that the Repairer and Active Cause are one. Nevertheless as I was introduced by an initiation, and the danger of all initiations is lest we should be delivered over to the violent spirits of the world, as happened to Adam when he initiated himself in his imagination and his desire was not all of God, I cannot answer that the spirit-forms that showed themselves to me may not have been assumed forms, for the door is open in all initiations. This is what makes these ways so faulty and suspicious. I know that Germany is full of these initiations. I know that the Cabinet of Berlin is guided and leads its king by their means. I can assure you that I have received by the inward way truths and joys a thousand times higher than those which I received from without."

The Abbé Barruel pours out his vials of wrath on Saint Martin, deeming him the leader of the subversive French

Illuminati. He is the original of Balzac's fine mystic, Louis Lambert. Indeed, the novelist has incorporated whole passages from *L'Homme de Désir*, a work published by Saint Martin under the pseudonym of *Le Philosophe Inconnu*. We have cited from his correspondence the passage where he talks of his initiation. His instructor was Martinez Pasquales. This man "presumed to be a Portuguese and a Jew," according to the *Biographie Universelle*, founded masonic lodges at Marseilles, Toulouse, and Bordeaux in the year 1574. He visited Paris and left for St. Domingo in 1777. He died there in 1779. His initiates were called Cohens, the Jewish word for priests. His occultism was based on the Kabbalah, and the Martinists and the Kabbalists, though distinct, were very much alike. Their god was the God of Spinoza (also a Kabbalist). They believed in an army of spirits—the spirit presiding over the sun's rising, the spirit presiding over the sun's setting, the crescent moon, the full moon, etc. Added to these were spirits of the second order—angels ruling the different stars, angels of life, death, victory, happiness, misfortune. All these spirits knew all the secrets of the past. To make them subservient the adept had to construct an accurate *grimoire*.

If this had the proper pentagrams, circles, triangles, and above all the properly spelt nickname of the spirit evoked, he would appear bodily and do all that was required of him. Thus the Spirit of the Rising Sun must be evoked under the title Ghenilia.

Saint Martin became the great advocate of intuitional occultism and the interpreter of Boehme. A phrase of his is much quoted: "The internal teaches everything, and protects from danger." But then it is quite plain that he did not hold that every occult whisper that comes into the mind of an untutored Theosophist is the direct voice of the Second Person of the Trinity. He says (Letter LXXIV.) that he could not have understood the fine internal occultism of Boehme, if he "had not been prepared by twenty-five years of wonders, both in deeds and intellectually." He told the Duchess of Wurtemberg that "an aged individual (Martinez) instructed him in many things, and left him at his decease important documents,

and became the cause of his thorough awakening." He had a "guardian angel" that he consulted freely. He lived in France in a world of marvels—

"As to the magnetic and somnambulist details you give me, I say little about them, because these things are so frequent amongst us that I doubt whether in any part of the world they have been so singular, or in greater variety. And as the astral has so much to do with it, I should not be surprised if a spark had fallen ~~into our~~ revolution, which may account for the complication and rapidity of its movements." (Letter LXVI.)

"I shall soon leave for my own country; not without regret, for there I have no friendships of the kind I want, and here I have several. I listen to everything. I see all that come, trying the spirits, according to the precept. There are some who have described to me beforehand almost to the very letter, the shaking we have just experienced, in which I have again seen how fortunate and powerful is the star that presides over our revolution. There are others who describe things to me of a higher order, the confirmation of which also frequently appears. They are all animated with the most lively faith and entire trust in the virtues and spirit of our Divine Repairer, which makes their intercourse sweet and wholesome."

Lavater was one of the real Illuminati. Indeed, oddly enough, he is coupled with Cagliostro in an attack made on the sect by Mirabeau on his return from Germany in 1788, under the title, "Essai sur la secte des Illuminés." The correspondence between Saint Martin and Kirchner gives a curious account of some magical practices in which he took part at Copenhagen. An occult society had been formed there by Cagliostro. They invited the Zurich clergyman to come and visit them, and paid the expenses of the journey. He found folks of the highest rank, some intimately connected with the court, engaged in evoking the dead.

"These men assure him that one of his friends, dead some time ago, will through his medium enter their society. They assure him that they have immediate communications with the active intelligent Cause." Kirchner

berger writes thus, and announces further that a sort of sacramental rite was performed. After prayers to the "Cause," the "Lord," a "manifestation" would appear that they called the "Spirit of the Lord," the "Image," the "Symbol of the Lord." A "cloud white as snow" would descend and rest upon them for about half an hour. This manifestation could be interrogated. If they asked it point blank if it was the active intelligent Cause, it ~~said~~ Yes! It judged them with severity.

"Take, eat, this is My body. Drink, this is My blood."  
"He who understands these words," says Lavater, "understands the deepest mystery, and most essential part of Christianity. He will be convinced of an union, real, positive, and intimate, with Christ."

This puts our old friend Cagliostro in rather a different light. That these sort of manifestations should occur long after he had left Copenhagen, shows that he must have been something more than a mere cheat. Kirchner gives a far more bewildering specimen of his work.

"For this reason, since these communications fall upon the external sense of sight, I believe they can take such superb outlines, forms so imposing and signs so awful, that it is hardly possible not to take them as true, even when they may be only counterfeits. A remarkable instance of this kind, which I heard of two years ago, is what occurred at the consecration of the Egyptian Masonic Lodge at Lyons, July 27th, 5556, according to their reckoning, which I believe to be incorrect. The labours lasted three days and the prayers fifty-four hours. There were twenty-seven persons at the meeting. While the members were praying to the Eternal to manifest His approbation by a visible sign, and the Master was in the middle of his ceremonies, the Repairer appeared and blessed the members assembled. He came down on a blue cloud, which served for vehicle to this apparition. Gradually he ascended again on this cloud, which from the moment of its descent from heaven to earth acquired a splendour so dazzling that a young girl, C., who was present, could not bear its light. The two great prophets and the lawgiver of Israel also gave signs of their

benevolence and approval. Who could reasonably doubt the fervour and piety of these twenty-seven members? Yet who was the institutor of the lodge? Who, though absent, ordained the ceremonies? "Cagliostro." "

It is impossible, at this distance of time, to get at the real Cagliostro. He was tried at Rome for being a Freemason; that was the charge. He was condemned to death, respited, and killed in prison for trying to escape. A life of him was drawn up under the inspiration of his judges, and this is all that we have to go upon.

Cagliostro, whose real name was Joseph Balsamo, was born in Palermo in 1743. He travelled much, visiting Greece, Egypt, Arabia, Persia, Malta, with one Althotas, whom he describes as the wisest of men. This person died at Malta. Cagliostro now visited the chief towns of Europe; and he boasts of having been on terms of intimacy with a great number of illustrious persons. He made many cures. He names the bankers in all these cities who furnished him with funds, but he keeps a secret the source from which his wealth was derived. He appeared at Strasburg in 1780, and excited the wildest enthusiasm by his acts of munificence. He was banished from Berlin by Frederick the Great, being ordered to leave in twenty-four hours. At the last stroke of the clock a Cagliostro in a calèche passed simultaneously through every gate of the city, to the bewilderment of the guards and their master. He is reported to have shown people the dead in a magic looking-glass. I have come across an old French book of Masonry, entitled *Acta Latomorum*. It affirms that he founded many Lodges, and altered many more. He professed to teach the Egyptian rites, but as a preliminary he exacted that all the archives and the library of the Lodge addressed should be destroyed, as modern Masonry was a pure farce. A correspondence between him and a Lodge in Paris called *Les Philalètes*, is given in the *Acta Latomorum*. He promises to "teach them the truth, and show them visibly and palpably God and the intermediary spirits."

When he was in London he published the following letter in *The Morning Herald* of Nov. 2, 1786:—

“TO ALL TRUE MASONS,

In the name of Jehovah the time has come when the new Temple of Jerusalem should be constructed. This is to invite all true Masons of London to assemble in the name of Jehovah (the sole name in which is a divine Trinity) to-morrow night, the third inst., at nine o'clock, at Reilly's tavern, Great Queen's St., to form plans and lay the first stone of the True Temple in the seen world.”

<sup>19</sup> In the same work I find it recorded that—

“At Warsaw, Cagliostro proposed to transmute metals in the presence of an Egyptian Lodge that he there founded. Instead, he decamped with a great deal of money, and 2,500 ducats' worth of diamonds (*Cagliostro demasqué à Varsovie*, p. 46).

The priestly biography goes much further than this. It announces that *Le Grand Cophte*, as he was called, promised a Jew named Marano, at Palermo, a vast hidden treasure. At the mouth of a cave the Israelite was induced to place a large sum of gold as a preliminary offering to the demons. Then Cagliostro, and this gold, and his confederates disappeared. The Jew afterwards recognised his spoliator at Strasburg, and that night he was assassinated by the confederates of *Le Grand Cophte*.

On the 20th June, 1786, Cagliostro, who was then in London, prophesied that the Bastille would be demolished and made into a public promenade.

We now come to Wieshaupt. In sketching the Illuminati I have left him to the last, because it seems very doubtful whether he dealt with the occult at all. Wieshaupt undoubtedly planned the greatest revolution that the world has ever seen; and yet in the biographies of the new edition of the *Encyclopædia Britannica* he finds no place. He was born in Bavaria about 1748. In 1771 he came across a Jewish merchant named Kölmer, who is said to have initiated him into Eastern occultism. Cagliostro was one of this man's pupils likewise. Again, the Sufis, or as Abbé Barruel puts it, the disciples of Mani or Manes, seem to have been active in their propagandism.

Wieshaupt became Professor of Law in the University of Ingoldstadt. There the injustices of modern society were pressed home upon him.

In the year 1776 he founded the sect of the Illuminati. His first disciple was "Ajax" (Massenhausen), for the secret society started with fine classical names. The second was "Tiberius" (Merz). Wieshaupt was the "Sparticus," to whom a famous letter was addressed by "Philo" (Baron Knigge). I have mentioned it elsewhere.

The founder knew from the first that he was playing with edged tools, which seems to show that his society was not an ordinary form of Masonry. "I know," he writes, "that with all my meditations my labours, my achievements, I am only twisting the hangman's rope, and fixing up my own gallows."

He writes also—

"Liberty and Equality are the inalienable rights of man, received from Nature in her primitive perfection. The first attempt against this right of Equality was the law of property. The first attempt against Liberty was effected by governments and political societies. The only supports of property and government are civil and religious laws."

Wieshaupt was brought up in a Jesuit school, and his organisation was borrowed from that order. Implicit obedience was enacted, and secrecy. At first an "Insinuating Brother" opened the campaign; but no names were given, and the novice was not taught very much. When the "Insinuating Brother" had prepared the pupil, the first grade was reached, and up to the sixth grade there was the ordinary harmless Masonry. In the sixth grade the novice became a "Scotch Knight," and he was required to send in a copious history of his past life. He still was quite unacquainted with the name of any single member of the fraternity except that of his "Directeur." The biography was written that the society might have a hold upon him.

"I have them now," said Weishaupt; "I know all their secrets."

This finished the "Lesser Mysteries."

For the "Epoptai," the seventh grade, a very severe cross-examination was set on foot, that the Brothers might judge how the aspirant would behave if his private safety and that of the order were at issue.



One curious question related to the secret doctrine:—

“Are there not traces of a similar secret doctrine in the old schools of the sages, in the allegorical lessons of Jesus Christ, the Saviour and Liberator of the human race, to his most intimate disciples?”

This passage seems to sum up Weishaupt's ideas:—

“Enlighten the nations! Take from the peoples their religious prejudices, their political prejudices. Seize upon public opinion, and under its empire you will find that the fabrics of all the governments will tumble into dust.”

Before the neophyte became a “priest,” a crown was produced, and a white garment, and he was called upon to choose. The crown meant worldly advancement. He was told that amongst the masked conspirators were men capable of pushing his career in court and camp. The white garment meant sacrifice complete, the dungeon, perhaps, and the gallows. This is the old Mithraic initiation. This is the crown offered to Buddha by Mara the Tempter, which is probably a veiled sketch of early Indian Freemasonry.

Supposing that the Illuminati were a vast organisation of lofty mystics banded together to give to mankind purer laws, purer creeds, more enlightened governments, would such an organisation be an unmixed good? Mystics like Anna Kingsford would say, “Certainly not. You are beginning at the wrong end. White Magic deals solely with Boehme's *Ladder of Jacob*. Spiritualise the individual, and the thrones of injustice will crash down. The Illuminati dealt in Black Magic. Their mysticism was politics, and Saint Martin had soon to give way to Marat.”

It may be mentioned that in the beginning of this century a quaint discussion arose: Were the Illuminati Jesuits? They had without doubt Jesuit organisation. From the débris of the extinct order they are admitted by the Abbé Barruel to have been largely recruited. The Jesuits have been at bottom always a purely political body. They had been suppressed, and they hated the Bourbon and the Pope.

## CHAPTER VI.

### *WILLIAM STAINTON MOSES.*

**W**ILLIAM STAINTON MOSES was born in Lincolnshire, November 5th, 1839. His father had been head-master of Donnington School. At an early age he went with his parents to Bedford, where there is an excellent college. Aided by the instructions of his father, he distinguished himself at this establishment, and obtained a scholarship for Exeter College, Oxford.

His mother was gentle and pious. She has recorded that on one occasion she saw her son, who sometimes walked in his sleep, go down into the sitting-room, and prepare a lesson that had puzzled him in his waking moments. He closed his lesson books. He put them carefully away. He then returned to bed without waking.

At Oxford the young man obtained a third class in Moderations in 1860. Great things were expected of him, but he worked too hard. At the end of his last term his health gave way. An interesting passage from a letter that I have received from Mrs. Stanhope Speer may be inserted here:—

“After this most serious illness he travelled abroad for a long time with intimate friends, and spent six months in a monastery at Mount Athos. After he became a medium his spirit guides told him that they had directed him to go there, in order that he might study that phase of the Eastern Church, and also gain time for meditation and rest.”

He returned to England in much better health, and wished to enter the Church. His doctor told him he might do this if he could find a quiet country curacy. He was ordained, and obtained work at a place near Ramsey, Isle of Man.

“I think he must have been at this time in his twenty-

fourth year, as he lived about five years on the island. We met him at the end of his sojourn there. He was then in his twenty-ninth year.

"During this time he worked very hard in the parish. He preached several sermons in the week, and was greatly beloved by the poor people. His vicar was an old man, and the parish a large one. During an outbreak of small-pox he visited the cases incessantly. And in one instance he not only ministered spiritually to the poor man, but nursed him, and helped afterwards to put him into his coffin and then to bury him. It was a bad case, and no one would go near the house. During this time he made many friends. He wrote for *Punch*, the *Saturday Review*, and other papers. He read incessantly.

"After remaining near Ramsey for I think five years, he accepted the curacy of St. George's, Douglas, Isle of Man. There he became celebrated for his earnest and eloquent preaching."

The year 1869 is an important milestone in the life road of Mr. Stainton Moses. To Douglas there came as a visitor, a physician of skill, Dr. Stanhope Speer. Mr. Stainton Moses became seriously ill. Dr. Stanhope Speer kindly attended him. In this way a warm friendship sprang up between Dr. and Mrs. Stanhope Speer and the young curate. The lady writes thus:—

"We were informed by our spirit friends that our meeting and subsequent friendship had been arranged in the spirit world."

As the internal life of Mr. Stainton Moses, and his occult experiences, will mainly interest us, we may here take leave of the clergyman. When he got better he went to Cheltenham for a visit, and there I first met him. In the autumn of 1869 he took duty in Dorsetshire. In the spring of 1870 he was appointed Lent preacher in the same county. There his health once more gave way, and he stayed for a whole year with his friends, Dr. and Mrs. Stanhope Speer, teaching their son. A document, signed by fifty of the chief parishioners of the parish of Manghold, Isle of Man, shows how his clerical labours were appreciated:—

"We beg to assure you that your labours have been greatly appreciated in the parish; the longer we have known you, and the more we have seen of your work, the more has our regard for you increased. The congregations at both the churches under your charge are very different in numbers from what they were some time ago. The schools have been better looked after. The aged and infirm have been visited and comforted; and the poor have been cheered and helped by your kindness and liberality. By your courteous demeanour, by your friendly intercourse, and by your attention to the duties of the parish generally, you have greatly endeared yourself to us all, and not least to our respected and venerable vicar, whose hands we are well satisfied you have done all you possibly could to strengthen."

In 1871 Mr. Stainton Moses became a master in the University School. Professor William Paice has borne testimony to his work here:—

"I can speak of his excellence as a public schoolmaster, not merely in his capacity of instructor, though in that all was good, but in his position of friend and adviser to his pupils. There his influence was admirable, and commanded a respect almost amounting to reverence."

This brings us to occultism. On this subject Mr. Stainton Moses at this time held much the opinions of an ordinary Oxford curate. He had tried to read Lord Adair's record of his private séances with Home the medium, but he had thrown down the volume in disgust.

The same failure had attended an effort to read *The Debateable Land*, by Dale Owen. We will let Mrs. Speer take up the narrative:—

"For two years I had heard of Spiritualism and occasionally read of it, but the facts had made no impression on my mind, though I had constantly heard of the subject from a cousin, who herself was deeply interested in everything appertaining to the 'return of the departed.' I was so ignorant at this time that when she first spoke to me upon this (to her) all-absorbing subject, I could not have explained the meaning of the words 'Spiritualism' and 'Spiritualist.' She became weary of talking to one

so little interested. But a change soon passed over me, from cold indifference to the warmest curiosity, which became painful until it was fully and completely satisfied.

“ March 4th, 1872. I was taken ill, and confined to my room for three weeks. During that time my cousin brought into my room, for Dr. S. to read (she was tired of lending me books on the subject, seeing how little I was interested), Dale Owen's last published work, *The Debateable Land*. I accidentally took it up, and began to read, and at once my indifference vanished, and I read and re-read, till I felt my mind and curiosity so aroused that I longed to get well and find out, with the help of others, whether the facts contained in this, to me, wonderful book were true or false. The feeling was so strong that I could think of nothing else. At night my father, whom I had lost some years before, seemed to haunt my dreams, and all day I was reading and pondering intensely over a subject that a fortnight ago I had taken no interest in. I suppose, like many others, I gave it no credence, and one cannot be interested in things unless one feels they are true.

“ March 26th. I was able to leave my room, and on seeing our friend, Mr. Stainton Moses, I asked him to read the book, and endeavour to discover whether it was true or false. I had not been able to arouse my husband's curiosity, as he was at that time almost a Materialist. Mr. S. M. had, up to the present period, felt as little interest in Spiritualism as ourselves, but, impressed with my great desire for knowledge upon the subject, he read the book, and became as anxious for information as I was. He at this time had a remarkable séance with Lottie Fowler, and Dr. S. seeing my intense desire for personal experience upon what seemed to me then the most important subject in the world, consented to join Mr. S. M. in visiting the medium Williams, and seeing for themselves. After a very few visits they were convinced that a force outside of the medium was at work, and from their experiences I wished to know more personally myself. The first time I ever sat was with Mrs. R. and my cousin, Mrs. C., on April 16th. After sitting for

some time the table rose up on my side. On seeing it do this I felt so startled that I also rose up, and went to the other side of the room. On returning we had only one or two more tilts, but could elicit no answers to our questions. From this time until June 3rd I sat with different friends several times, with but little result.

"On June 3rd, Mr. S. M. and self sat with Mrs. C. and Miss A. C. We then had raps near Mr. S. M., and a few tilts of the table; more than we had had before. After this we met several times, Dr. S. and Miss E. joining our party, but nothing ever occurred except slight rapping, always near Mr. S. M. I was getting weary of such constant failures, and my husband then proposed having the medium, Mr. Williams, to sit with us.

"On July 17th we held a séance with him. Our party included, besides ourselves and the medium, Mr. S. M., Mrs. C., and Miss A. C. We sat for two hours in a little study, round a small table, all joining hands for the whole time. The medium had no friend with him, and his hands were held during the séance, so that they were not free to do anything. In the room was a large bookcase, covering one side; also a pedal harmonium, away from the table—a square table, round which we sat; another table away from us, covered with books and music; and one empty chair in addition to those on which we sat. The room was full of books and music. We sat at first with a little light; we had raps and quivering of the table. We then put out the gas, and continued our séance in darkness. The raps were very loud—louder than any I had yet heard—and they sounded very startling in the complete darkness in which we were sitting. I confess I felt startled, and not over comfortable, but my anxiety to know the truth for myself kept me at my post. Mr. S. M. was touched three times. Dr. S. then exclaimed, 'Something is crawling up my face.' It seemed to be a hand passing up and down his face, and lifting up his beard. All mortal hands in the room were held. What could this be? Mrs. C. and Miss A. C. both shivered, and said they were touched by something strange. I felt nervous, and requested to be left alone. I was not yet prepared for the touch of spirit

hands. They evidently recognised the fact, and did not touch me, though the others felt touches several times during the two hours we sat. After some time had elapsed I did feel something cold, but very tangible, laid across my hands. On mentioning the fact, it was discovered that the only vacant chair, some distance from the medium, had been brought from its position, lifted on to the table, and gently put on our hands. A little bell was merrily rung round the circle, and then placed on the chair, which stood upright in the centre of the table. Correct time was beaten on the table while some of the party sang. We heard the harmonium blown, and notes sounded; books and music were brought from all parts of the room and placed on the table, or put into the hands of the sitters; and a large music-book was brought through the closed door of the bookcase and placed on the table in front of Dr. S. The door was fastened, and Mrs. C.'s chair pressed up against it; it could not have been opened unless she had moved, and the chair also. Ghostly figures were seen flitting about the room, and two bright spirit lights, like stars. At the conclusion of the séance a roll of music was picked up, and the spirit known as 'John King' said through it 'Good-night, God bless you all,' and then tossed it into my lap, as much as to say, 'Though I may not touch you, here is an evidence of my presence.' It was all very startling, coming to people who knew they could trust each other, whose hands were joined all through the séance, the medium's never once loosed, the door locked, and even if any one had wished to enter they could not have done so secretly, as the gas was burning brightly outside the study door. Mr. Williams had never been in the room, or, indeed, the house, till he came to this remarkable séance. He himself seemed surprised that so much should have occurred in a circle he had never sat with before. I was then convinced that what I had so read of and pondered over was true, and that my mind, in a strange, unaccountable manner, had been suddenly awakened to look into it for myself.

"After this séance we sat two or three times with Mrs. C. and her sisters, but very little was elicited beyond

numerous small raps, always in the neighbourhood of Mr. S. M., who was by degrees developing into a medium, and who with Dr. S. had attended several public séances, and had been informed at those séances that he would have great mediumistic power.

"After sitting at home with various people, and getting very little result, we became tired, and proposed, one evening, that we would try by ourselves—Mr. S. M., Dr. S., and self. Accordingly we did so on July 30th, 1872, in the same room, and with the same table that was used when Mr. Williams was with us. For the first time the raps became intelligent, and answered a few questions. We sat again the following evening, under the same circumstances. Raps louder and more frequent; the table quivered and moved several steps; raps also answered questions. I was still nervous, sitting in the dark in the midst of such ghostly visitors. I remarked, 'I do not think the spirits can care for me,' when they rapped out instantly, 'Yes.' This showed me they could either read our thoughts or hear our words.

"After this séance we parted from Mr. S. M. for a short time. We had taken a furnished house for the summer months at Douglas, in the Isle of Man, and he was going to visit old friends in the north of the island, intending to join us afterwards, when we hoped to renew our investigations together."

This début of a great medium is highly interesting. It shows that at starting he had no more power than any other novice at work at table turning for the first time. It seems also to shake our faith a little in the hocus-pocus of Kabbalistic magic. Mr. Stainton Moses, with a few friends, soon experienced phenomena far more astounding than any that Eliphas Lévi, with his pantacles and Hebrew letters, his conjurer's dressing-gown and sprig of verbena twisted in his hair, could ever boast of. In point of fact the yoga of Brahmans, of Kabbalists, of Catholic mystics, is in essence the same. All depends on passivity, perseverance, solitude.

Mr. Stainton Moses has given his account of these séances, which began April 2nd, 1872.

"The first of the sittings held by Dr. S. and myself



with Herne and Williams took place on May 30th, 1872, at their rooms; 61, Lamb's Conduit Street. We sat at a very heavy oaken table, first in the light, then in darkness, without result; and adjourned to June 5th. Herne did not enter an appearance, and we left, feeling very suspicious, to meet once more on June 8th. Herne again failed to appear, and we commenced a sitting with Williams. Presently Herne came in, but no results were obtained. I had gathered from my reading that some persons stopped manifestations by absorbing the force, especially if they were undeveloped mediums. I proposed, therefore, that I should leave the room. I did so, and manifestations soon occurred. The table moved, some chairs tilted, and were brought up nearer to the circle. The movements were very palpable when I returned after ten minutes' absence. I took my place at the table, and all was quiet. I went away again, and they recommenced. Herne's chair was lifted, and he was thrown to the floor with a loud clatter. I returned, and we determined to sit in the dark. Still no results, and at last we stood up. A clear, distinct tapping was heard over the mantel on the wall. I asked if my presence stopped manifestations. Three clear raps, louder than any we had had, eager, it seemed, to make the cause of failure plain. 'Must I go?' Yes. 'Can you not try to do something in my presence?' Yes. We sat down, and faint taps came. I put the question through Williams—the previous ones had been put through Herne, for the Spirits apparently could not hear me—'Have I any mediumistic power?' Yes. (Very decided raps) 'Has Dr. S.?' No. More raps, and I tried to question for myself, this time successfully. Was there a friend of mine present? Yes. Any message? Yes. Through the alphabet was spelt out, 'Do not be so sad. She will soon be b——' There it ceased, and though I asked often I could get no more. I was in anxiety as to the serious illness of a close friend, who did soon after recover.

"But it was after the raps had ceased that the most extraordinary manifestation of force took place. Herne had been twitching and jerking as was usual with him when any phenomena were about to occur. As we sat

with joined hands round the table these mysterious twitchings were communicated to me. I felt them first in my face, then I quivered all over, and finally my right arm was seized about the middle of the forearm—I distinctly felt the grasp, soft but very firm, of a hand—and my hand was dashed violently up and down, beating on the table with a loud noise. My jerking was communicated to Herne and Williams; Dr. S. alone was unaffected. It was the most tremendous exhibition of ‘unconscious muscular action’ I have ever witnessed. It left the ball of the thumb and the hand generally so sore and bruised that I could hardly hold a pen or use my hand for some days. I felt as if power was taken from me, and the mediums remarked that power was being taken for some manifestation. So it was. Herne was raised in the air and lifted bodily on to the middle of the table, his chair leaning from the mantel-shelf on to the table where he had been sitting. At the same time a chair, or chairs, fell in the room near, or at my left side: one was placed on my knees, quite gently, with a soft gliding motion, and a gentle touch or pressure as though to draw my attention. My hand was painful, and we closed the séance. I threw open the folding doors and went into the next room. Whilst there Dr. S.’s hat was thrown from the far end of the room, where no one was. . . . As we left the room I turned, about half-way down the stairs, to speak to Herne. The door of the room in which we had been sitting was open. No one was there, we had all left. The door was clear in my line of vision, and I saw a chair sailing out of the open door about two feet or two and a half feet from the floor, and coming towards us.

“These private séances did not yield any more advanced results, and were abandoned in favour of other developments. On subsequent occasions I have tried making magnetic passes over a good-sized square table with perfect results. I have held it in a position similar to that shown above by the same means. I have also caused a large dining-table, capable of seating eight people, and very heavily made, to move and tilt in obedience to the movement of my hands without contact. A remarkable

case which occurred in his dining-room (36, Russell Square) is recorded by the late Serjeant Cox, in the second volume of his work, *What am I?*

“On Tuesday, June 2nd, 1873, a personal friend, a gentleman of high social position, a graduate of Oxford, came to my residence in Russell Square, to dress for a dinner party to which we were invited. He had previously exhibited considerable power as a Psychic. Having half an hour to spare, we went into the dining-room. It was just six o'clock, and, of course, broad daylight. I was opening letters; he was reading the *Times*. My dining-table is of mahogany, very heavy, old-fashioned, six feet wide, nine feet long. It stands on a Turkey carpet, which much increases the difficulty of moving it. A subsequent trial showed that the united efforts of two strong men standing were required to move it one inch. There was no cloth upon it, and the light fell full under it. No person was in the room but my friend and myself. Suddenly, as we were sitting thus, frequent and loud rappings came upon the table. My friend was then sitting holding the newspaper with both hands, one arm resting on the table, the other on the back of a chair, and turned side-wise from the table, so that his legs and feet were not under the table, but at the side of it. Presently the solid table quivered as if with an ague fit. Then it swayed to and fro so violently as almost to dislocate the big pillar-like legs, of which there are eight. Then it moved forward about three inches. I looked under it to be sure that it was not touched; but still it moved, and still the blows were loud upon it.

“This sudden access of the force at such a time, and in such a place, with none present but myself and my friend, and with no thought, then of invoking it, caused the utmost astonishment in both of us. My friend said that nothing like it had ever before occurred to him. I then suggested that it would be an invaluable opportunity, with so great a power in action, to make trial of *motion without contact*, the presence of two persons only, the daylight, the place, the size and weight of the table, making the experiment a crucial one. Accordingly we stood upright, he on one side of the table, I on the other side of

it. We stood two feet from it, and held our hands eight inches above it. In one minute it rocked violently. Then it moved over the carpet a distance of seven inches. Then it rose three inches from the floor on the side on which my friend was standing. Then it rose equally on my side. Finally, my friend held his hands four inches over the end of the table, and asked that it would rise and touch his hand three times. It did so; and then, in accordance with the like request, it rose to my hand, held at the other end to the same height above it, and in the same manner.

"I have now reached a halting-place. The summer vacation was at hand, and we were all leaving town to meet by the seaside. I have compiled my narrative from copious notes written immediately after each sitting, occupying 114 closely written 8vo pages in my first book of records. My experience of public séances will now give place to records, at the proper times, of phenomena in our private circle. I have thought it well to show the kind of preparation I had for what was to come after. I had by this time gained considerable experience, and had developed a good deal of latent mediumship, which was ready to break out when circumstances called it forth. Dr. S. was greatly interested in the physical phenomena, and no more. He began the investigation as a pure materialist, and his experience, while it convinced him of the action of abnormal force, and even of the reality of the spiritual beings with whom we were brought in contact, did not really affect his materialistic tone of mind to any great extent. Practically he remained a materialist to the end, and, when phenomena ceased on my higher development, the ease with which the spiritual side of his experience was abandoned, while his hold on the reality of the phenomena never varied, showed how little of the spiritual there was in his spiritualism. Mrs. S., on the contrary, had little interest in the physical phenomena, while spirit-teaching sank deep into her mind, and exercised a profound influence on her beliefs. She was always a thorough spiritualist, in the highest and best sense of the word. For myself I am pretty well known, and hold firmly the beliefs that I evolved in such sort and by such means as I have described."

Let us listen now to Mrs. Stanhope Speer:

"During our separation he had been visiting in a town in the north of the island, where he had lost a valued friend. On August 17th he joined us at Douglas, and on the same evening we renewed our investigations. We had chosen for our séance-room one that led out of the dining-room: a compact, sombre-looking apartment, with a stained-glass window, so that little sunlight ever came into it. Mr. S. M. and myself were alone; Dr. S. had not yet joined us. Just as we were sitting down, waiting for him, before turning down the gas and locking the door, the table rose up, and came down with so loud a noise that I confess to feeling greatly startled. This evening the raps were varied, continuous, and some very loud. We counted seven different sounds. Distinct answers were given to questions. We were informed that there were forty-nine spirits in the room, all good, appointed to take charge of the circle.

"During the time we were at church raps were heard by each member of the circle in different parts of the pew in which we were all sitting. On our return Mr. S. M. found on his bed three things removed from his dressing-table, and placed in the form of a cross on his bed. He called Dr. S. into his room to see what had taken place during our absence. Dr. S. heard loud raps on the footboard of the bed. He then locked the door, put the key in his pocket, and left the room vacant for a time. We went to dinner, and during our meal the large dining-table, covered with glass, china, etc., repeatedly moved, tilted, and rapped; it seemed to be full of life and motion. Raps accompanied the tune of a hymn our little girl was singing, and intelligent raps followed our conversation. We paid several visits to the locked-up room, and each time found an addition had been made to the cross. Dr. S. kept the key, unlocked the door, and left the room last. At last all was finished. The cross was placed down the centre of the bed; all the dressing things had been used that our friend had in his travelling dressing case. Each time we went into the room raps occurred. At our last visit it was proposed to leave a piece of paper and pencil on the bed, and when we returned again we

found the initials of three friends of Mr. S. M.'s, all dead, and unknown to any one in the house but himself. The cross was perfectly symmetrical, and had been made in a locked room that no one could enter, and was indeed a startling manifestation of spirit power.

"August 19th. Mr. S. M. and Dr. S. sat alone, and had letters and pamphlets brought to them, *taken from the room in which I was then sitting, in the light.* Papers and gloves were thrown on the table; also a quantity of scent. After this I went into the room, and on sitting down a message was given through raps on the table, 'Can't my medium rest?'

"August 21st. A book was brought from one room to the other; message rapped out, 'To convince.' On my going into the séance-room to join the gentlemen, raps came on the table; message given, 'Let Mrs. S. sit.'"

This very remarkable story of the crosses formed and then altered and increased several times, is given at greater length by Mr. Stainton Moses himself.

"August 1st, 1872. I left London for my summer holiday. The psychical development, which had been steadily going on, was evidenced by a case of very distinct clairvoyance. I was an inmate of the house of an old friend who had just died, and I clairvoyantly saw the spirit form on five several occasions: once most distinctly in the death-chamber by the side of the discarded body.

"I rejoined my friends, Dr. and Mrs. S., at Douglas, Isle of Man, on August 16th. Our séances were of the usual character up to Sunday, August 18th. The events of that day were so remarkable that I give my own version of them from copious notes taken at the time. Mrs. S. has already given an outline of the occurrences, but it is impossible to give any fair idea of the nature and persistence of the phenomena from breakfast to 10 p.m. Raps followed me wherever I went, never ceasing at meals, in church or anywhere. At breakfast a butter-knife was lifted out of a deep dish and thrown on the table under the eyes of us all. The dish was in the centre of the table, quite away from any person. On returning from church I found on entering my bedroom

(which adjoined the drawing-room on the first floor) that certain objects had been removed from the toilet table and placed on my bed in the rough form of a cross. These were a travelling desk, a pocket-book and a fly-book (containing flies for fishing).

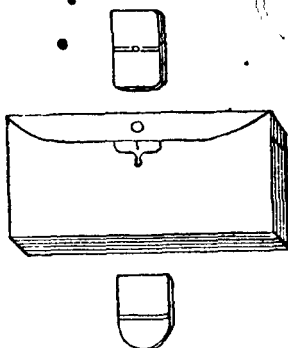

FIG. 1.

**Not by**  
**Sri Basanti Bhattar 'Set**  
 8/1-A, Math, New Garden Lane  
 Calcutta - 700006  
**NOT EXCHANGEABLE AND**  
**NOT SALABLE.**

" I immediately called Dr. and Mrs. S. to see what had been done. Having in mind the evidences of the presence of spirits I instinctively referred this movement of objects to their action. There was, indeed, no one in the house who would be at all likely to play tricks, and, as will be seen, we guarded against anything of the kind by our subsequent precautions. When Dr. S. had looked over the room, under the bed, in cupboards and wherever any one could be hidden, he went away, whilst I prepared for luncheon. I was sponging my face and afterwards found that my black skull-cap had been moved from its place and hung on the foot-board of the bed. I went to fetch Dr. S. to see this new manifestation, and while I was gone, my collar, which I had removed and placed on the toilet table, was placed symmetrically round the top of the cross, which now assumed the form shown in Fig. 2.

" We examined the room once more and found nothing concealed. At my suggestion Dr. S. locked the door and put the key in his pocket, having bolted the windows before leaving. At lunch our conversation was punctuated with raps of remarkable crispness and precision.

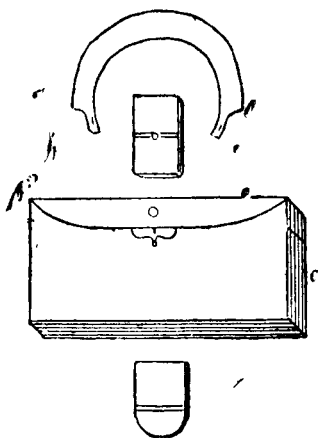

FIG. 2.

There were also loud scrapings on the back of my chair, which was repeatedly moved to and fro. The meal over, Dr. and Mrs. S. and I went to the locked room, and found that the cross had been increased in size by the addition of a clothes-brush and hat-brush from my dressing-case, which lay open on the toilet table.

"Locking the door once more, we returned to the dining-room, and found abundant indications of spirit-presence. Raps were loud on floor and walls, on the table, and on the back of my chair. A tune drummed on the table and sung by one of the children was accurately imitated. The heavy dining-table, with all that was upon it, was moved out of its place three or four times. After this had gone on for some time, Dr. S., at my suggestion, went alone to the locked room. On unlocking the door he found that two other articles from my dressing-case had been added to the cross, and so told us on his return. I believe the reason for my not going with him on this occasion was that I felt overpowered by the strong influence that surrounded me, and was half entranced."

To sum up Mr. Stainton Moses's story, the bedroom locked up on each occasion was visited three times more.



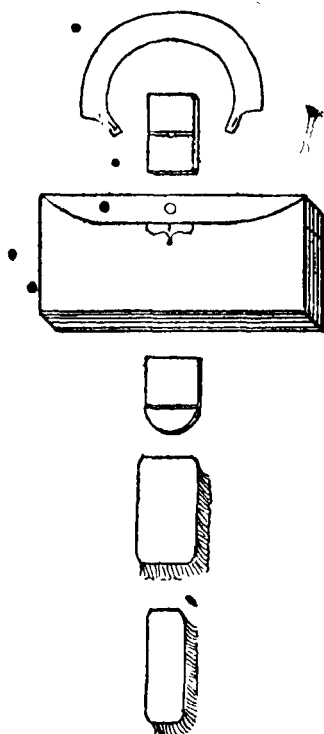

FIG. 3.

Each time fresh objects were added to the cross." Its final appearance was as shown in Fig. 4.

Here are some more experiences.

"On Tuesday, August 20th, Dr. S. and I went out fly-fishing. He called my attention to the fact that he had seen a pebble fall near my feet, and said that, from the trajectory, it must have been thrown from a point quite near. He said he saw it in the air. Shortly after a small stone fell in the water near me as I was wading in mid-stream: and afterwards a stone the size of a pigeon's egg was quietly slid into my left hand as it hung down behind me while I was throwing the fly with a light one-handed rod.

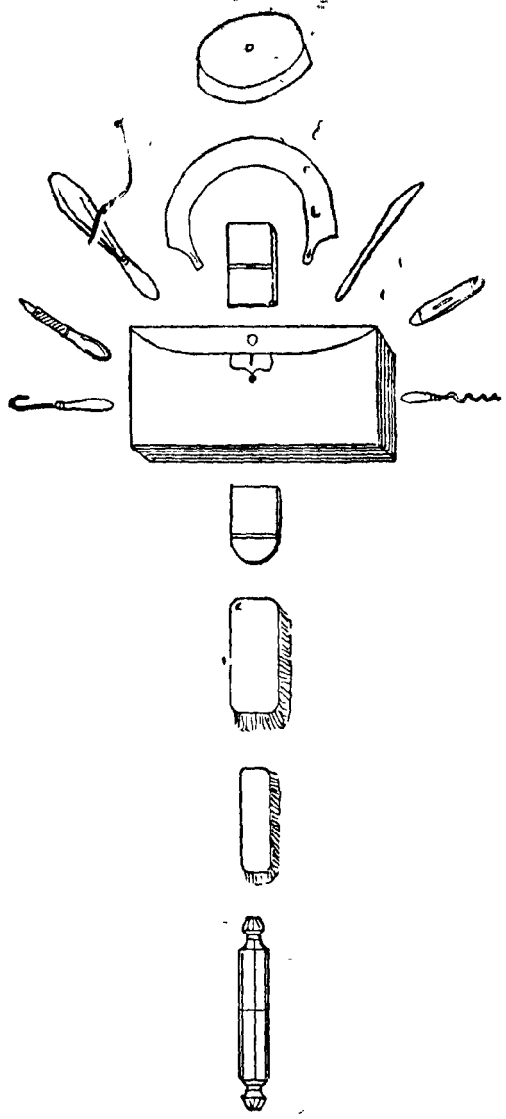

FIG. 4.

"At a séance on the 19th a little homœopathic book had been brought into the room and put into Dr. S.'s hand. On the 21st he and I were talking in the dining-room by the window. He could not positively remember whether the book had been taken from a shelf near where he was then sitting. I was strongly impressed—and I had become very amenable to these accountable impressions—to go into the adjoining room, which we used for our séances, and ask the question of our unseen friends. We did so, closed the folding doors, and soon the table tilted, raps came, and alphabet was called for. *To con* was rapped out, but Dr. S., who was rather deaf, could not hear and changed his place, coming close to me. The raps were made much more loudly, and *-vince* was added, making *To convince*. Immediately some object was placed close to his hands. It was a small copy of Milton's *Paradise Lost* from the shelf in the other room near which Dr. S. had been standing. Both Mrs. S. and I had had it in our hands during the evening. The whole affair did not take ten minutes, and we went back to the other room, and I to my interrupted cigar. It was just a comment on our conversation intended to convince a very punctilious critic that the object *had* been brought through closed doors from that shelf.

"In reference to the writing referred to by Mrs. S., I find a note in my book: 'I am unable to state of my own knowledge anything more than the fact of my hand having been seized and impelled to write. Dr. S. tells me that the characteristic feature was the enormous rapidity with which the message was written. Mrs. S. attempted to guide my hand, which, she says, was perfectly rigid. In some places the writing is indistinct, from the fact of the lines having crossed each other from imperfect guidance of my hand. The writing presents a bold, firm character, quite unlike what might be expected from the rapidity with which it was written. I was partially entranced during the writing, and felt oppressed and weak after it was done.'

"The crown to which Mrs. S. alludes was composed in the same way as the cross had been made, but I found it complete, and it was not added to, though it was altered

after I found it. Of course, the door was not locked when it was found, nor were any precautions at that time taken against possible trick. We did not expect any such manifestation, and we knew that there was no one in the house who would play tricks on us. The alteration was on this wise:—

“At our usual evening séance we were aware of being sprinkled with wet scent, which seemed to fall from the ceiling. Subsequently I found in the outside pocket of the jacket that I was wearing a scent bottle, which had formed part of the crown to which illusion has been made above. When Dr. S. locked the door and took away the key with him, that scent bottle was undoubtedly on my bed: the crown being complete and symmetrical. Yet it was in my pocket now, and the scent that it had contained had been showered upon us till it was nearly empty. On going to my room we found that the bottle had disappeared from its place in the crown, which was obviously and palpably vacant.

“After this I felt my chair raised off the ground. It was a common occurrence for it to be pulled back, partly turned round and moved, so that I sat with my back to the north. Frequently, it would be drawn back from the table into a corner, while the table was moved in the opposite direction, and I was thus left completely isolated, and unable to reach the table at all.

“When we sat in the dining-room we always sat in the light: for dark séances we used the inner room.

“As I was seated in the corner of the inner room my chair was drawn back into the corner, and then raised off the floor about a foot, as I judged, and then allowed to drop to the floor whilst I was carried up in the corner. I described my apparent movement to Dr. and Mrs. S., and took from my pocket a lead pencil, with which, when I became stationary, I made a mark on the wall opposite to my chest. This mark is as near as may be six feet from the floor. I do not think my posture was changed, and I was lowered very gently until I found myself in my chair again. My sensation was that of being lighter than the air. No pressure on any part of the body: no unconsciousness or entrancement. From the position of the

mark on the wall it is clear that my head must have been close to the ceiling. My voice, Dr. S. told me afterwards, sounded oddly away up in the corner, as if my head were turned from the table, as it was according to my observation and the mark I made. The ascent, of which I was perfectly conscious, was very gradual and steady, not unlike that of being in a lift, but without any perceptible sensation of motion other than that of feeling lighter than the atmosphere. My position, as I have said, was unchanged. I was simply levitated and lowered to my old place."

This is sufficiently astounding; but a report got abroad amongst students of occultism that Mr. Stainton Moses had been levitated and had written his name on the ceiling at the first séance that he had ever been present at. We see from this that he was already by this time a bit of an adept. In any case the experience is a strong one for one who was a novice five months before. We give extracts from his letters:

"October, 1872.

"I am getting wonderful messages written, and altogether am having remarkable experiences. I have also had the voice speaking to me very plainly. I must write and give you an account when we meet.

"I have little or no tapping now; but at night, since I have been ill, I have heard a whispered voice speaking to me. When I first heard it I thought it was my own fancy, but after sponging my face and going into the next room I heard it still. It directed me what to do for my throat, and generally took care of me. I inquired if it were the voice of my guardian, and was told Yes. I also asked if it were looking after me, and was told, Always. I remarked that it was a very nice arrangement. I asked for something to convince me that this writing and voice were not merely subjective. I was told that I should have a sign given me to confirm me, but that I was to ask no more. Accordingly I was directed to empty my desk (the same used in the formation of the cross) of everything but paper, pen, ink and pencil. I did so, putting into it only a large envelope cut down the sides so as to open out. The desk I closed, placed it in its cover,

and then inside my cupboard, in which I kept papers. I was told to leave it twenty-four hours. On opening it I found direct writing of the most beautiful description. In the centre of the paper was a cross, as usual, and two messages, one in Latin and another in Greek. The Latin was :—

In hoc signo vinces.  
(With this symbol thou shalt conquer.)

“The Greek was an adaptation of the salutation to the Virgin, but the gender changed and adapted. The whole was beautifully written in ink. Of course, the paper must have been taken out of the desk, for matter is no bar at all to spirits. It is altogether the most astounding evidence. It seems as though they would heap together evidence of the unreality of matter and of their power to overcome its bar. Doubtless they could write as well on a sheet of paper in the heart of a stone wall or inside a fire-proof chest.

“You are at full liberty to make any use you like of my letters. You will know, of course, whether there is any private matter in them. But they are utterly inadequate to convey the notions which I should wish to convey: written hurriedly and amid the buzz of boys. My work here is very pleasant, English composition, which is my delight. I have little else, and find my course easy and pleasant, and work well within my power.

“The band have not all left you: but you forget the means of communication has. They evidently cannot reach you now; the bridge is gone, that is all. I will sit and ask about you.”

At this point we pause. It is not yet the time to consider how the various sections of modern thought judge phenomena such as we have just described. But a report has got abroad that Mr. Stainton Moses was credulous, visionary, easily imposed upon. “He lacked,” says Mr. Myers, “all vestige of scientific and legal instinct.” No words, as it seems to me, can fly more wide of the mark.

Mr. Stainton Moses in these days was a strongly-built, broad-shouldered, muscular Christian. The religion of Jesus has many faces. There is one that endeared it to

Madame Guyon. There was one that endeared it to the Duke of Wellington: Certainly the Christianity of Mr. Stainton Moses approached nearer to the latter than the former. He was earnest, clear-sighted, methodical, thoroughly honest, thoroughly matter-of-fact. He loved the order of Ritualism, but he hated its priestly assumptions and priestly beadedness. With his Christianity centred in the atonement. It was a "common sense" religion, high reward for faithful but exact services. And the seer was from the first as methodical as the curate. His visions were all neatly copied out into MS. books, each with lock and key and an index. The following quaint summing up is copied from one of them,—

"I cannot get a definite result on account—

"1. Of the extreme difficulty I find in verifying alleged phenomena.

"2. Of the vast amount of pure sentiment and rant that is written on the subject.

"3. Of the startling nature of phenomena credibly attested, which utterly upset all one's notions of the fixed laws of nature.

"This last difficulty meets one on all hands; *e.g.*, an object is brought from one closed room to another through locked doors. A live coal is placed on a man's head and the hair is not singed. A table rises without contact of hands, and remains suspended over the floor. A belief in such statements involves the revision of preconceived opinions as to physical laws. Nevertheless I cannot resist the weight of evidence as to the existence of certain phenomena. They are attested to me—

"1. By my own experience and eyesight.

"2. By the witness of credible persons with whom I have conversed.

"3. By the published testimony of many persons on whose evidence any reasonable statement would be believed.

"I cannot believe that my senses have so frequently and so completely deceived me, and always with a similar tendency. If so, my senses are untrustworthy, and my evidence on all matters inconclusive."

Here is another passage:—

“For a long-time I failed in getting the evidence I wanted, and if I had done as most investigators do, I should have abandoned the quest in despair. My state of mind was too positive; and I was forced to take some personal pains before I obtained what I desired. Bit by bit, here a little and there a little, that evidence came; and as my mind opened to receive it, some six months were spent in persistent daily efforts to bring home to me proof of the perpetuated existence of human spirits, and of their power to communicate and give evidence of their unimpaired individuality, and of the unbroken continuity of their existence.

“Some of those who came I had known during their life on earth, and was able not only to verify their statements, but also to note the little traits of manner, peculiarities of diction, or characteristics of mind that I remembered in them while in the body. Most were unknown to me, and came always in obedience to the controlling spirit (who arranged everything), to give their evidence and go their way when the task assigned them was done.

“Some came at the time of death. At that time it would seem the spirit finds it easy to manifest its presence, and the facts that it can give are readily capable of verification. Some had been long dead, as men count time, and came back in a dazed and awkward fashion to revisit the old scenes of earth, cramped and straitened, as it were, by taking on again the old conditions. But wherever they came from, and however they communicated, one and all bore with them an air of sincerity and earnestness, as of those who were themselves impressed with the deep significance of the work they had in hand. And all, without a lonely exception, told the truth about themselves, so far as we could verify their story. Many statements were from their nature not capable of proof; a vastly greater number were minutely accurate, and none suggested any attempt at deception. I cross-examined these invisible witnesses in every conceivable way, and with a pertinacity that left nothing untried, to elicit facts.

“Referring to records, I find that when I was staying



at Shanklin, Isle of Wight, the guest of Dr. Speer, we had a continuous chain of testimony at our daily sittings, all bearing on the question of identity of spirit. The evidence was given in various ways, principally through raps on the table; many of these raps produced entirely without contact of the hands of any persons present. Some facts were given by direct writing, on previously marked papers; some by automatic writing, some through clairvoyance or clairaudience. In a few cases corroborative evidence was drawn from all these sources.

“During twelve days, eleven different cases of identity were made out by facts and dates. Three of them were entirely unconnected with any of us; and of one of them none of us had ever heard the name or any particular. Yet his full name, his place of residence, and the very name of his house, date of his birth, and day of his death, were given with perfect accuracy. One was connected with Dr. Speer, five with Mrs. Speer, and two were friends of my own.”

## CHAPTER VII.

### MORE EXPERIENCES.

AT these séances a spirit came who announced himself as Mr. Stainton Moses's "spirit guide." He first communicated by tiltings of the table and raps. He called himself "Imperator."

But by-and-by a great advance took place. "Imperator," as Mrs. Speer announces, "entranced Mr. S. M. for the first time. We were sitting quietly in the dark when I was startled by hearing a strange voice speaking slowly and solemnly. It said, 'I am here.' 'Who are you?' I asked. 'Imperator.' Dr. S. said, 'Will you tell us of things past and future?' 'Things of the past I will tell you, but of things to come we are not allowed to speak.' We then asked if that was really the spirit of my father that we saw at the Holmeses? 'Yes.' 'Is he good and happy?' 'Very.' 'And gone to a high plane?' 'He is always with you, and will fetch you when you enter spirit-life; he is more really living than you are.' His parents were not near him. He also said it was quite right to sit—we had not quite lost the fear of this strange, new thing—and would do us good; also that it was my father who influenced me to inquire into the truth of Spiritualism. He had been much with me, and was near me now, the best guide I could have, as he was a very good spirit; he also said our boy (whose musical gifts were very marked) was inspired, but we do not know by whom. We cannot yet impress this medium as we wish, he continued, on account of his bad health and unbelief. If you sit regularly you will hear many things, and in time the world will also know of them. In answer to a question, Imperator said there were many spirits between himself and the Great Spirit. He told us

at the end of a long and interesting conversation to remain quietly passive for ten minutes. He knocked on the table after the control had ended.

“ ‘Imperator’ soon made another announcement:—

“ ‘I have been with him nearly all his life, and it is a great pleasure to control him. His doubts are worth more than most men’s faith. When first attached to him I was in the sixth sphere, now I am in the seventh. Very few spirits ever return to earth from those distant spheres; but God has sent me for a special work.’ In answer to a question as to why he had come to us:— ‘Some one must be chosen for our work. Evil influences you need not fear, as they will not come near you unless you court them; evil is from within more than from without, and if you have been brought up amid holy influences, and afterwards court unholy companionship, the soul must suffer. In this life the great thing is to do your duty, or you must suffer loss hereafter. Life is unending and progressive. The soul never stands still: it must improve or retrogress. When it retrogrades it is in the state your old theology calls death. No one ever gets near to God. He sends spirits to act between us and Him, and prayer helps the soul. People born in poverty and vice, with but few opportunities for good, will have their education in the other world. The lowest spirits, those hovering near the earth, are the ones that most frequently manifest at circles and simulate characters that do not belong to them. If you will meet often and wait in patience we will do much for you.’ ”

It must be recollected that “Imperator” had one great object in view. That was to develop the mediumship of Mr. Stanton Moses. To effect this he had to tackle the religious difficulty. When a ritualistic curate first finds himself face to face with Spiritualism, he calls to mind many texts forbidding “witchcraft,” and condemning the sin of “seeking the truth from the dead.” We will go deeper into this question when we come to the automatic writing of “Imperator” through Mr. Stanton Moses. At the séances the spirit was patient and cautious.

“ We are sent to communicate to the world, and power

is given to us within certain limits. The men you honour and call great have from all time been used by the Almighty as channels, and are inspired by spirits to become great and honourable. When this influence is removed from them they sometimes lose much of their greatness, as they are nothing in themselves—vessels of God through which His influence is pointed by spiritual agency. Hence it is that Milton, under spiritual guidance, was great; without that he would have been worthless; and if you could converse with him now you might, perhaps, find him quite different to what he was in earth-life, and his communications on a lower plane. This may account for your difficulties with regard to the trifling nature of the communications given by many spirits who come with great names. They are often also personating spirits, and not those they pretend to be. This has troubled your minds, troubles the medium still. For this reason it is often better not to give the name of a spirit communicating, as they may be so altered, when the spiritual influences they enjoyed on earth are removed, as to be unrecognisable. Then, in the other life men must retrograde. In the other life, as you phrase it, but as I should say, the next phase of your being (this is but your infancy), spirits do not retrogress; they are not the same when the influence they had upon earth is removed; but if they have done their earthly work well, God uses them again for further work. Man is but God's channel, made for His purposes. It is difficult to make you understand how entirely man is made as a vessel of God, acted upon through spirit agency, to do God's work."

Here is a letter to Mrs. Stanhope Speer:—

"August 1st, 1875.

"I have had very little spiritual communication—no writing at all. There seems to be a lull. I have had lots of letters about 'Occult Science.' You will see my letter in the *Medium*; and people have sent me some funny little books, which I have tried to read, but I don't make much out of them.

"Two of my correspondents have incontinently written to ask me to stay with them. One is a clergyman near

Banbury, and seems a very nice fellow. He has been a student of the occult for thirty years. Another lives in Bristol, an adjutant of Engineer Volunteers. Three or four write from London.

"I am told that Mentor, Chom, Said, Kabbila, Prudens, Philosophus, and Dr. Dee are acting together and influencing my mind in the direction of the stores of ancient knowledge that are laid up. It is a curious thing how completely my mind has been turned in that way, though I really know and care very little about the subject, and a month ago had no desire to look into it. It shows how completely these intelligences can direct and turn one's mind. I begin to think that they mould the mind as they will, even in those who are unconscious of their influence. Their band is a very powerful one—Mentor, an Arabian philosopher; Philosophus, the great Italian philosopher, the philosopher *par excellence*; Kabbila, an Indian philosopher; Prudens, who was more skilled in the Occult Alexandrian and Indian lore than any who ever lived; Chom and Said, priests, of Isis and Osiris, skilled in all the wisdom of the Egyptians; and Dr. Dee, the great Occultist of England. They ought to have enough knowledge among them to save me the trouble of wading through musty old tomes. But it does not seem to be part of their plan ever to save one trouble. It seems that the bringing of those gems has had to do with this phase of development. I see in all the books that I have read—especially in one of Paracelsus that I am now reading—very much about gems and their properties, and the aid that they give in intercourse with the world of spirits. Next to them they make most account of perfumes. It is curious how we have had these two things in such abundance. This knowledge of gems it was that caused the old Alchemists to be reputed as transmuters of metals and gems. It was not that they did really transmute or make gold and gems for themselves, but that they were requisite for promoting spirit intercourse. These old philosophers worked in secret, and the outside world knew nothing of what they did. They purposely wrote in a way that was intelligible only to the initiated,

and which the outsiders misunderstood. The ancients seem to have known and understood every form of manifestation which we see and do *not* understand now. They could command them. We cannot. By a very careful study of conditions they arrived at a pitch far ahead of ours. A man did not hesitate to devote his whole life to the careful study of one point; and he would as soon have spoiled his conditions by the introduction of another person as Tyndall would scatter sand over his phials and crucibles, in the midst of some delicate experiments. They laboured so secretly that in many cases their learning died with them. But I can find traces in some of them of a knowledge of materialisation, both of crystals (that especially) and of animate bodies.

“The difference between them and us is that they lived in ages when these things were of rare occurrence, and consequently they studied and worked at them, and dared not let people know what they were doing. They surround us on every side. We have no difficulty in observing them, and so they are made a mere gazing stock, and we surround them with conditions which, in other ages, would have prevented their occurrence. The result is that there is not a single man living who really knows how the physical phenomena are caused, or can get at the intelligence which moves behind them, so as to command them as the ancients did. I believe, as I said in my last letter to the *Medium*, that it depends on our acquiring this knowledge whether we fix the present wave of spiritual influence, or lose it when it ebbs again.

“There have been some very subtle and beautiful perfumes here. My mother can't at all make out where they come from. Three little pearls also made their appearance on the table the other day. I have also had a little ruby, and sapphire, and emerald: all small—the size of your rubies.

“Mentor was the cunning workman who fashioned the cameo. He is not content with his work, which he says was bad, and that he can do much better. He actually carved it, he says. And I see no reason to doubt it, seeing that I can find no limit to spirit-power. If they are allowed to work in their own way they can do almost

anything. It is only when we compel them to work in lines prescribed by us that they find any difficulty.

"We are on the very threshold of the subject: even those who know most. The vast mass of Spiritualists have no sort of idea of the matter, and I doubt whether this age ever will have."

Here we again revert to the diary of Mrs. Stanhope Speer:—

"February 21st. This evening Mr. S. M., Dr. S., Mr. Percival, and myself dined at Mrs. Macdougall Gregory's, to meet the Baron du Pôtet, the great French mesmerist, and others. During dinner I felt a cold and very disagreeable influence in the room, and was so uncomfortable, that I longed for the repast to be over. The Baron and Mr. S. M. said they felt the presence of a troubled spirit in the room, one that had very recently left the body. I noticed, when the gentlemen joined the ladies after dinner, Mr. S. M. looked very strange, and altogether unlike himself. He said he felt an inclination to write, and asked for paper and a pencil. He sat down, and his hand wandered over the paper without any result being obtained; he then requested the Baron to help by putting his hand over his. This he did, and Mr. S. M.'s hand was then violently controlled, and his face became very flushed. After drawing something on the paper (we could not recognise what it was) his hand wrote: 'I killed myself to-day in Baker Street. I threw myself under the steam-roller.' It then struck us that the drawing was intended to represent the figure of the brass horse sometimes placed on the front of a steam roller. The spirit appeared in the greatest trouble, and asked for our prayers. Mrs. Gregory came and offered a prayer over the medium. This influence remained with him for some time, making him feel ill and uncomfortable. He was visiting at our house, and when he went out in the morning he was right and well; but I noticed on his return that his mood had quite changed, and that he was depressed and restless, and this lasted during our drive to and from Mrs. Gregory's. The next morning inquiries were made, and we found that a man had been killed the previous day in Baker Street by the steam-roller passing over him. Mr.

S. M. had passed over the place on an omnibus soon after the occurrence, when the spirit attached himself to him.

"The following evening, Sunday, we held a short séance, but the conditions were disturbed, owing to the unnatural control of the previous evening. Scent was showered over us very abundantly, and there was much spirit-light in the room. H. answered questions with his light. The medium was withdrawn from the table; we were told to keep very quiet and wait, but he was still restless and uncomfortable, and would talk. They tried to control him, but found it, in his restless state, impossible. After waiting some time Theosophus rapped, 'We will write: join hands.' Soon after light was asked for, and we found on one piece of paper we had placed under the table, some Egyptian writing, and on the other, 'Hail, we greet you. × THEOSOPIIUS. † T S D.'

"January 8th, 1874. This evening we met under the usual conditions at 9.30. Our séance-room had been scented more or less all through the day. As soon as the light was extinguished, fresh perfume was perceived by the circle. H.'s light was also visible, and remained with us for some time, moving about in every direction. We then saw large masses of floating light, and soon heard distinct raps on the table. On asking who was rapping, the name 'Mary Stanton' was given. Mr. S. M. said: 'Who are you? Any relation of mine?' 'Yes.' 'What?' 'Grandmother.' 'Will you give date of your death?' 'Yes, June 21st, 1851.' 'Your age?' 'Eighty-eight.' 'Day of birth?' 'April 6th.' 'What brought you here?' 'I have come by request of Imperator.' 'Which sphere are you in?' 'Fourth.' 'Will you give me your mother's name?' 'Jane.' 'And your father's?' 'John.' 'Your maiden name?' 'Kirkham.' 'Do you know Mrs. Bradley's maiden name?' 'Gilby.' 'And her Christian name?' 'Mary.' The medium asked if she remembered him as a little boy? 'Yes.' He then manufactured two stories, purporting to be incidents in his early life, and asked her if she remembered them. To both she gave a distinct negative. I was surprised to hear her deny the facts, as I was not aware, until the conclusion of the séance, that Mr. S. M. had fabricated



them, as tests. He inquired if she still held the same Evangelical views she believed in when on earth? She said they were modified. The Divinity of Christ was untrue, as generally understood. 'Will you write for me through Imperator or Rector?' 'No I may not.' The spirit rapped, 'God bless you.' I said to Mr. S. M., 'Ask if you are right in seeking for spirit manifestations.' He declined to do so, but the spirit returned, called for alphabet, and through it gave, 'You are right.' After she had departed, Mr. S. M.'s chair was suddenly drawn from the table, lights became visible, and much rapping occurred. G. came, answered questions, and told us to 'cease.'

Students of occultism have often been puzzled on the subject of what they call their spirit guides. "Why," it is asked, "should my mother, my dead sister, keep away from me, and why should some spirit who lived a hundred years ago be always by me?" An answer to these sort of questions was given at one of the sances of Mrs. Stanhope Speer.

"September 15th.—This evening strong lavender scent was quickly perceived by the circle; it had evidently been made from some lavender I had gathered and placed in the room before the sance, as I wished to see whether our spirit friends would utilise it. They wafted the dry scent over us, and rained much wet perfume on the circle. It was all lavender scented. Catharine rapped, and G. made some clear musical sounds. Dr. S. asked whether the other musical friends were present. G. answered 'Yes,' and the message was then given: 'They give way to the Ch. of.' After some time had elapsed, Mr. S. M. became controlled, and Imperator held a short conversation with us. He said he had been absent on work concerning the mission, and had tried to put us into communication with our lost friend. For the present the experiment had failed, as the spirit was one who was not attracted back to earth, and had no mission or power in herself to return. This power was something akin to the mediumistic power possessed by some mortals."

Imperator said that the sances were not to be con-

sidered apart from the "Teachings" delivered automatically by the hand of the medium. All were links in one chain.

"The pattern life is to you the model of what man may become, pure and holy, ennobled by suffering and elevated by charity. To that life you may look; following it, it will rescue you from sin, and lead you to that which is noble. You err in following too closely the words of fallible men, or building on them an edifice, the foundation of which is error, and the superstructure fallacy.' After further conversation Imperator said: 'The B. is here to-night; he has been trying to speak, or communicate by raps.' 'We are unfettered by time or space, and it is impossible to convey to you the ideas of spirit-land. The B. was with the medium last night, though unable to communicate. A vast future is before this medium, but of this we can give you no idea. We are, as you, waiting, and we do not hazard anything at present. We may seem to be too cautious, but we cannot make statements depending upon remote contingencies beyond our control. Other mediums are being prepared, but there are none from whom we expect results such as those we get here. They will be subsidiary agents. It is very difficult to raise up mediums, but we fully recognise the importance of doing so. The hardest minds to influence are those who would be most valuable to our work."

With Mr. Stainton Moses we seem to be constantly living in a world of fairyland. I recollect hearing from his lips a very strange story. He announced that according to an arrangement with friends in Paris, he reclined in London on a sofa to see if his non-atomic body could be projected to a photographer's studio in Paris. This occurred February 4th, 1875.

Here is the testimony of Mrs. Stanhope Speer:—

"Since our last meeting the medium's spirit, by appointment with Mr. Gledstones, had been taken from its body at Clifton Road, London, at eleven o'clock in the morning, and was, between that hour and twelve o'clock, photographed on a plate in M. Buguet's studio in Paris, while he was in deep sleep in his bedroom in London. Mr. S. M. came to our house at four o'clock the same

day, and in the evening we held a séance. Emperor soon controlled, and told us great care had been taken during the experiment. He himself had watched over the medium's body, keeping it in a state of trance, while the spirit, also entranced, had been taken by its guides to Paris, and there photographed. Plotinus, who went with the medium, would also be seen on one of the plates. Emperor further said that a spirit's leaving its body was no new occurrence, as it dated back to the incarnation of souls into our world. This medium's spirit had often left his body, though it had not been photographed until now. The spirit was magnetically attracted from the body, and it then followed its guides. Had the body been suddenly startled it would have caused grievous injury, and the sudden awakening would have caused death—a death most painful. Hence great care and caution had been necessary. In a day or two Mr. S. M. received the two photographs from Paris. His entranced spirit was in one, standing behind Mr. Gledstones, and on the other was the draped figure of Plotinus, also standing near Mr. Gledstones, as Emperor had informed us it would be at our last meeting. Mr. G. also wrote an account of what had transpired in Paris, and this agreed with Emperor's information.

“December 6th.—This evening we sat alone in the séance-room. Raps were soon heard in all directions. Scent came abundantly. G. manifested, and the room was filled with spirit-light. After several convulsive movements, Mr. S. M. became entranced. Emperor spoke in a very clear voice, saying that the control was good. He prayed the blessing of the Supreme might be with us always. We then held a long and interesting conversation. He informed us the control had been imperfect on the previous evening, as the room had been full of spirits anxious to communicate, and our spirit-guides had been obliged to use up the power. Emperor described the earth as the seventh sphere, as there were six spheres below it, and seven above, and seven beyond—spheres of contemplation. The seven beyond the earth were spheres of work and probation—progressive spheres. Spirit influence had more to do with our lives than we

imagined. We were judged of by the spirits surrounding us. Before we knew this medium, influence of a spiritual character had been brought to bear upon us preparatory to forming this circle. After much more conversation Emperor bade us farewell, saying he was not sure whether he would be able to control again; would do so if possible. Mr. S. M. then became greatly convulsed, and when quiet we were startled by hearing a deep solemn voice saying: "God guard you, friends. Through the mercy of the Most High and kindness of the Chief, I am come to you through my dear and valued friend." We asked who was speaking to us, and the answer given was 'S. W.' 'You have wished for evidence of the departed. I died. I have come back. I live the *same* man, the *same* spirit. It is strange, very strange, to come back again, and I find it difficult to speak; another time it will be easier.' He described his passage into life as instantaneous, without pain, a sudden awakening into life. With all his shortcomings—and they were many—he could look back upon his earth-life as a life of useful work, honestly done. After answering questions, he gave us a solemn blessing, and departed. The voice was unlike any other we had ever heard in the circle, and was very like the deep, beautiful one of the late Bishop. It made a deep impression upon us, and we felt we were in the presence of the spirit so lately departed from earth. In a few moments the voice changed, and Emperor again spoke to us. He said he was rejoiced that the Bishop had been able to talk to us; hoped it would have been easier on account of the perfect *rapport* between him and the medium. We then spoke of the pleasure it had given us to welcome G. again. 'Yes, he is standing by you now.' Emperor then said to G., 'Come here.' Instantly the light that was standing by me moved to the medium's side, and G.'s sounds were heard very distinct and sweet. Emperor conversed for some time, said the conditions were very good, and that in time, if we were patient, much evidence would be given to us. We were not to admit other influences, as it increased the difficulty of communication. Even now the manifestations often gave great trouble, and it took

them many hours to prepare for a séance, as one thoughtless act might completely disarrange their plans. Imperator then said he would not keep the control longer for fear of injuring the medium. He prayed earnestly for the circle, and then departed. We remained very quiet. Presently we heard Mr. S. M. saying: 'I see a beautiful spirit. It is G. There is the Bishop with his own familiar face and expression. And there is Catharine.' I saw bright clouds of light in the direction he pointed. Catharine was standing between me and Dr. S., who said: 'If my little sister is here, will she rap?' She instantly did so, close to him. I asked her to manifest near me. She rapped gently between my hands, which were resting on the table. The beautiful spirit-light seemed then to vanish, and Mr. S. M., still in trance, said, in a most mournful tone of voice: 'They are all gone, and now it is dark, dark, so dark, and cold; the reality was there, the shadow was left.' The control had been so perfect that when the medium came out of it he knew nothing that had occurred during the séance, not even any control. All was to him an absolute blank."

Perhaps the shrewd reader will guess the name of the Bishop. Besides bishops they had theology.

"We were speaking, when we last met you, on the question of the different phases of religious truth, *i.e.*, on Gentile religion or the religions of nations. As regards the fate of those whom you call the heathen, the majority of Christians decide that they will fare badly in the hereafter, being left to the justice of the Supreme, without any claims on His mercy. It is strange that they should have forgotten that Christ has said that there are other sheep not of the Christian fold, who will be brought in and judged according to their works. So in the account of the Last Judgment (allegorically described) you will find it stated that all the nations of the earth are separated into two detachments, as a shepherd separates his flock; some on one side, some on the other, according to their works. Paul, again, addressing the Athenians on Mars Hill, speaks of God as Omnipotent, and as having made of one blood all nations of men on the earth, and describes

mankind as sprung from one family; all yearning after God, if so be they might find Him. Paul and Jesus both stated the idea that God is manifested as man can receive Him, in all parts of the earth, and that fragmentary manifestations of the Supreme have been given in all ages. The religion of India will be our first subject. Its sacred records date back to between thirty-seven and thirty-five hundred years. Brahminism teaches that there is nothing without God; Spinoza, that there is nothing but God. The oldest of the Brahminical philosophers propounded the true doctrine of the spirit enshrined in a body, composed of five elements, within which was the spirit-body, indestructible through the ages. The spirit-body to them was a divine truth. Brahminism was too ideal and transcendental; it made naught of time and much of eternity; naught of man and much of God; and from its unpractical character was of little use to its votaries. Buddhism was a reaction against this one-sided view of truth, and instead of teaching only of the Divine Essence, it dealt with your plane of existence, and with man as a personal being.

“March 10th. This evening we sat alone under our usual conditions. G. was the first to manifest. He commenced playing outside the circle, and then on the table. By request he made tambourine sounds in the air above our heads. Delicious verbena scent was wafted over us, and then brought in a liquid form, and thrown over our hands and handkerchiefs. It remained on them all through the night, and the perfume was very sweet the next morning. H.'s light was bright and flashing. We then heard many sounds round Mr. S. M. Imperator controlled with difficulty. I inquired as to the spirit L, that I had met at a strange séance. He said he had not yet discovered who it was, but he thought it was a personating spirit. Mentor had been told to find out about her. I then inquired if I might again meet the same circle (I had been sitting with two mediumistic friends on the previous day when the spirit referred to claimed to know me and the circle). Imperator said he had always wished from the first that the circle and members should be kept isolated and free from the influence of other

circles. It was more important now than it had ever been, as the adversaries were on the alert, waiting and watching to bring discredit on our mission. Hitherto the circle had been kept pure and truthful, and it was their great desire that it should continue so.

“November 21st.—This evening, as soon as we had put out the lights, the room appeared full of spirit light, and quantities of delicious scent, both dry and liquid, were wafted and thrown over the circle. The ‘fairy bells’ played over the centre of the table. Mr. S. M. then saw a luminous hand dropping some things, which, we discovered, on striking a light, were pearls of three different sizes. The message was given through raps, ‘We have brought three kinds; preserve them, they are precious.’

“November 22nd.—This evening, while at dessert, in full light, we heard raps on the dining-room table near Mr. S. M., and two pearl beads were placed on the table. Later on we went into the séance room, when many more pearl beads were brought, also a quantity of scent was thrown over the table and circle. We changed the room for a short time. While waiting in the lighted drawing-room beads were placed in three different places in the room. On our returning to the séance room, a shower of the same kind of beads fell on to the table and floor, apparently from the ceiling.”

An experience of Mr. A. A. Watts may be inserted here. The “we” refers to his wife, the talented daughter of William Howitt.

“We made the acquaintance of Stainton Moses—as he has recorded in his work, *Spirit Identity*, p. 61—at a dinner-party at Mrs. Cowper Temple’s, March 28th, 1874. He greatly impressed us by his frank ingenuous address, his modesty and gentleness, and his large experience and thoughtful appreciation of the questions in which we were interested. We were all of us at that time—as indeed one is still—occupying ourselves with seeking evidence of the identity of the spirits claiming to communicate with us, and a curious series of incidents, which had then recently occurred, united us, in an interesting manner, in our common quest. The details of them are given in the work before referred to; but I will venture

to extract them here, for the purpose of confirming the account given, in so far as we were concerned:—

“On February 10th, 1874, we (that is the circle at Dr. Speer's) were attracted by a new and peculiar triple tap on the table, and received a long and most circumstantial account of the death, age (even to the month), and full names (in two cases four, and in other three in number), of three little ones, children of one father, who had been torn from him at one fell swoop by the angel of death. None of us had ever heard the names, which were peculiar. They had passed away in a far distant country—India; and when the message was given there was no apparent point of connection with us.

“The statements, however, were afterwards verified in a singular manner. On March 28th, 1874, I met, for the first time, Mr. and Mrs. A. A. Watts, at the house of Mr. Cowper Temple, M.P. Our conversation was concerned chiefly with evidence of the kind that I am now summarising. I recounted various cases, and among others, the case of these three children. Mrs. Watts was much struck with the recital, which corresponded in outline to a very distressing history which she had just heard. On the Monday previous Mr and Mrs Watts had dined with an old friend, Mrs. Leaf, and from her had heard a distressing story of bereavement which had befallen the relative of one of Mrs. Leaf's acquaintances. A gentleman residing in India had, within a brief space of time, lost his young wife and three children. Mrs. Leaf entered fully into the melancholy details, but did not mention either names or the place of the sad occurrence. In reciting the incident of three young children communicating with me, I gave the names and the place, as they had been furnished to me in the messages. Mrs. Watts undertook to ascertain from Mrs. Leaf the particulars of the case she had mentioned. She did so on the very next day, and the names were the same.

“Through the kindness of Mrs. Watts I made the acquaintance of Mrs. Leaf, and was much impressed with the perfect correspondence of every detail given to me with the facts as they occurred.

“It is not a little remarkable that, on the very day on



which this communication was made, Mrs. Watts, who possesses a very beautiful gift of automatic drawing, which had for some time been in abeyance, was impelled to draw three cherubs' heads, which, she was afterwards spiritually informed, were drawn in typical allusion to this sad event. Other details, symbolic of the country in which it occurred, and of the attraction of the mother's spirit to her three little ones, were added. The drawing forms a very striking illustration of the various methods employed by spirit to reach various types of mind. Mrs. Watts—at that time, be it noted, unknown to me—had always been instructed in the language of symbolism, by poetic simile, and by artistic representation. The Voice appealed rather to Spirit and to the inner consciousness than to the outer sense and to methods of exact demonstration. I, on the contrary, had not progressed so far. I was on a material plane, seeking for truth after my own fashion, and craving hard logical demonstration. So to me came hard facts, clearly given, and nothing more. To her came the symbolic indication, the artistic delineation, the poetry of the incident. The source, however, was one. It was Spirit manifesting truth to us according to our several needs.'

"To this account I find, in my copy of the book, the following memorandum in my wife's writing: 'This proved by date in diary' (meaning her own diary) 'showing spirit drawings made upon the same day that the little spirits came to "M. A. Oxon"; then unknown to us.'

"With these bonds of union our acquaintance became more and more intimate, and finally settled down to a friendship maintained, without intermission, for the rest of the lives of two of us and in tender memory by the survivor.

"Stanton Moses was then in all the stir and strife of the movement, with all the energy of early middle life, and in the fulness of his mediumistic power.

"I must here permit myself a moment's digression to observe that Spiritualism was not, when he joined it, or, in so far as I am aware, at any time becoming 'a degrading superstition,' as you, with perhaps not unpardonable exaggeration, have been pleased to describe it. There

were no doubt in its ranks then, and may possibly be even now, foolish and indiscriminating persons, deficient in judgment and power of exercising sober imagination. Such there are in all associations of human beings upon any subject whatever, and it is to be feared will always be, until some nostrum shall have been discovered for confining the right of opinion to the wise.

“But to resume. He was then a prominent figure in the Society which was interesting itself in London in these matters; and to our own less lively circle, he was glad at times to resort for sympathy and mental repose. It interested us to hear what was going on in the world, and it interested him to tell us. But in the midst of it all, the question of spirit identity continued to occupy and occasionally to perplex us.”

I will insert here the testimony of my friend, Mr. F. W. Percival:—

“The mediumship of Mr. Stainton Moses was so varied in character, that it is impossible to illustrate it adequately by single instances, but when the time arrives for estimating its special value, I think that all earnest Spiritualists will attach the highest importance to the continuous chain of testimony, bearing on the question of the identity of spirit, of which many records have appeared in your columns. I therefore venture to send to ‘LIGHT’ another case of identity, which will, I think, be new to most of your readers.

“The séance which I am about to describe was held at the house of Dr. Stanhope Speer, on December 20th, 1874, and the circle met under the usual conditions. Soon after it commenced, the medium described two spirits, those of a woman and a child, who gave the name of Death; he said that they were not bad spirits, but that they seemed to be in great distress, and very anxious to communicate. ‘They are speaking to me,’ he said, ‘but I cannot hear distinctly what they are saying.’ Their influence appeared to distress him, and he moved his chair as if to get away from them. The disagreeable influence was also felt by all the sitters, and we therefore broke up the séance for a time. When we resumed sitting, the medium said that the two spirits were still

there, and as they evidently distressed him, we were very glad when he told us that he saw them being turned out of the room. A spirit very familiar to the circle then came, and rapped out, 'All right now.' The medium was then controlled by Imperator, who said:—

"We were prevented from coming sooner to you to-night by an influence which disturbed the conditions. These two spirits came by our permission to derive benefit from the atmosphere of the circle. All Nature is sympathetic, and they would have been benefited by your influence. They are the spirits of a woman and her child, and one of them passed away from your earth under peculiar circumstances of sorrow, by which she is now hampered. A painful and sudden death is a great distress to a spirit, and hence wise men have taught you to pray against sudden death—that is to say, a death for which you are unprepared—as the spirit suffers loss by the premature withdrawal from the body.'

"We inquired how they were benefited by coming to the séance, and were told that the room was assimilated to the atmosphere of spirit, and that these spirits could throw off in it something of their earth atmosphere. After a few more remarks had been made, the control was interrupted, and at length Imperator said that as the spirits named Death had returned, and were very anxious to communicate, he thought it better to allow them to do so.

"Communications were then given by raps with considerable difficulty, and the following facts were elicited: The woman's name was Euphemia Matilda Death. She had passed away at Aldershot on November 21st, 1874, aged twenty-two years, having been the wife of a veterinary surgeon. Her child, named Ellen, had died on November 4th, aged twenty months. On returning home, the medium was told that the child's full name was Edith Ellen, that she had been hurt accidentally, and had died in great pain, aged fifteen months. The mother died suddenly, he was told, at the South Camp, Aldershot, and her husband was in the Army Service Corps.

"It appeared that the spirits could not rest until the



the most beautiful one they ever heard. He also wrote a prayer, which I can answer for as being one of the most beautiful I have ever seen. He spoke for more than half an hour on the spirit photographs, the soul-substance, and spirit progress, the latter being the subject on which he waxed so eloquent. Unfortunately I have no record; only the prayer was written down. The spirits all bowed to Imperator, just as I have seen them before. Mr. C.—a great philanthropist, of Bristol, who died last month—came and spoke, so that all knew him. He invoked Imperator, and gave us a few words in his own voice. He was a Quaker. Then the Rev. Mr. D., a Presbyterian minister, came. And then a spirit controlled the medium to rise and pray over me, and then to kneel down by my side and sob, as in gratitude; then to go through a vivid portraiture of a death-bed scene at my feet. I did not recognise the spirit, but it seemed to have been some one whose death-bed I had watched, and to whom I was the instrument of good. The spirit had returned to thank me. It was a most striking scene. They all said they had never seen such a séance, or heard such words, even from Home's best séances. He is very well known here, having stayed once more than six weeks with Mr. Beattie. By the bye, when I got into my carriage at Paddington, I found Home sitting in a corner of it. We travelled down together. He went on to Plymouth. I had much conversation with him, and am confirmed in my first estimate of his character."

This seems at first sight very matter-of-fact, two mediums meeting. But in a few days, Mr. Stainton Moses learnt that at the date of his journey Home was in Russia. It was a phantom Home that he had talked to. He got into his carriage and stepped across a stranger concealed behind a newspaper. He himself read for half an hour, and then, looking up, recognised Home. Some will hold that this was a case of mistaken identity, but Mr. Stainton Moses was, to the last, of opinion that it was the spirit-body of Home. He had a long conversation to judge by. And Imperator, at a subsequent séance, told him that it was really Home. They parted at Clifton.

We are dealing chiefly with the spiritual life of Mr. Stanton Moses. In point of fact, his outside life was uneventful. He worked very, very hard at his school. He wrote for many papers, chiefly occult—the *Medium*, *Human Nature*, the *Spiritualist*, the *Psychological Review*, and, lastly, *Light*, which he by-and-by edited. His *nom de plume* was "M.A., Oxon." He was offered the joint editorship of a leading weekly—a lucrative post—but he preferred doing gratuitous work, to push ideas that he believed to be far more important. In point of fact, he worked himself to death, breasting steadily the stream, instead of going with it. Also, he got up more than one Psychic Society, the Association of Spiritualists, the London Spiritualist Alliance; and he was instrumental in getting up the Psychical Research Society. But he left this when he found, as he believed, that they were determined not to emerge from pure materialism. Afterwards, on one occasion, he came to an amusing collision with them.

They had taken up the subject of psychography, and many long "papers" appeared in their "Proceedings," showing how this, especially in the case of a medium named Eglinton, was simple conjuring. For psychography, the medium, with his four fingers, holds a slate against the under side of a table, his thumb alone being visible above. A crumb of slate pencil is placed between the top surface of the slate and the bottom surface of the table, and questions unknown to the medium are then answered on the top surface, his fingers touching only the bottom surface of the slate. The Psychical Research Society attributed this miracle to—

1. The "mal-observation" of the spectator.

2. The fraud of the medium, who furtively always contrives to read the question, in spite of all precautions, and then dexterously shifts slates for the answer. At a pinch, he is so skilful that he can write long messages on the side of the slate that his fingers do not apparently touch.

Now Mr. Stanton Moses, to test this "mal-observation" theory, went off to Mr. Eglinton, with two friends specially selected for their shrewdness. His report, with comments, is published in the *Proceedings*, vol. iv. p. 340.

Two slates were carried to the séance, one marked with a rough blue cross on one side and a blue circle on the other, the second slate being similarly marked in green. The Psychological Research critics hold that these marks "might have been imitated on other slates," but this would imply considerable drawing and colouring skill on the part of the medium, a box of colours ready at hand, and very much "mal-observation" on the part of the three witnesses, who sat by him, watching him all the time.

Dr. Johnson, one gentleman, wrote: "What is the sum of  $50 \times 60$ ?"

"We all turned away from the table," says Mr. Stainton Moses. "It is certain that none of us could see or know what was written."

"No reason is given for certainty that Mr. Eglinton could not see," says the Psychological Research critic; but surely the word "us" includes Mr. Eglinton.

The slate was then held under the table in the way I have described. Dr. Johnson and Dr. Stanhope Speer carefully watched the latter, "without any lack of continuous observation," says Mr. Stainton Moses, "as I can testify assuredly."

"If 'M.A., Oxon,' can assuredly testify to the continuous observation of Dr. Speer," says the critic, "he must have been continuously observing him, in which case he cannot also have been efficiently observing Mr. Eglinton."

But here, I think, the Psychological Research critic is a little too astute. Let him sit at breakfast to-morrow with three others, at a small table, and he will find that his eyesight can take in all three.

By-and-by a correct answer came on the slate, on the side held against the bottom side of the table.

A second experiment was made. Mr. Eglinton has two slates working on a hinge. These slates can be locked up. A blank cheque, folded in four, was selected at random from several others by Dr. Johnson. They were in the pocket-book of Mr. Stainton Moses, but neither he nor any one present knew the number of any one of them. Mr. Moses carefully placed the folded

cheque in the slates. Dr. Johnson locked the slates. "At once" the sound of writing came. On examination, the number of the cheque was correctly given.

"I think it probable," says the critic, "that a lapse of memory—a complete omission—has occurred in respect to this experiment, and that though the fact has been forgotten, the locked slate was held under the table for a short time, directly after the cheque was enclosed. It was then, I suspect, that Mr. Eglinton read the cheque."

To avoid one miracle we sometimes fall into another. Three gentlemen especially wideawake—I knew them all—had come to narrowly watch Mr. Eglinton. Could they have been weak enough to let him do all this? They say positively that the locked slate was "all the time in full view."

In point of fact, as we have already seen, Mr. Stainton Moses and his friends had had strange experiences of psychography through his own mediumship. I will give, from the journals of Mrs. Stanhope Speer, the most wonderful of all:—

"March 22nd This evening Mr. P. and Mr. H. joined our circle. Raps came quickly on Mr. S. M.'s chair, and the table. G. manifested musically; H. flashed his light; and the voice again attempted to speak. There was much cool scented air wafted over the circle. We heard a peculiar noise between Dr. S. and Mr. S. M. It sounded like a man with a wooden leg striking the floor. We inquired who it was, and through raps we were told that it was the Baron Guldenstamme. The messages given were 'Je vous salue' and 'Nos amis d'en haut.' We were then informed that he had been with the circle for some time, and was much interested in it. The medium became greatly convulsed, and beat the table with his hand. When a light was struck, we found a message and prayer written too small for natural sight to read. It was read with great difficulty by the help of a strong magnifying glass. No one could have written it in the light, much less in a darkened room. The message given was:—

"Doctor salutes you, good friends. It is long since we have been able to communicate with you. We have been absent from you for a while, being engaged in work



• which is pressing. • But we endeavour to provide that our absence should not be injurious. We have helpers many, who do not suffer you to be without protection and guidance. It is now more than ever necessary that both you and we be wary, for the Adversaries beset us round on every side, and imperil our mission and mar our work. You have been warned of this, how that the undeveloped will be able to retard our mission and mar the good work. Be wary and pray ever with zeal and earnestness, lest you be hurt by the machinations of the foe.

“Oh, Thou Supreme All-Wise God, Creator, Preserver, Benefactor, Friend of all Thy children! Thou Adorable and Beneficent Source of all good! Thou Great, Glorious and Sublime Embodiment of Essential Love!

“Thou Whose Fatherly care is over all Thy creatures, who sufferest not the sparrow to fall unheeded!

“Look, O Father, with pitying eye on Thy children in their strait!

“Great God, enable us and them. Strengthen the feeble, confirm the wavering, and cheer the sorrowing souls!

“Thou knowest, Father, the needs of all Thy children. Thou canst see the hidden thoughts. Thou takest count of all their strivings. Mighty God, strengthen our work amongst men, that the Adversaries may no more prevail!

“Spirit of Love, shed abroad charity and good-will amongst mankind!

“Spirit of Wisdom, pour forth Thy Godlike gifts upon this earth!

“Spirit of Knowledge, be amongst them, a Guide and Teacher of Truth!

“Spirit of Power, be here, a mighty aid in time of trial!

“Spirit of Purity and Holiness, keep Thy children pure and free from taint of conscious sin. May they realize their blessings, their helps, their difficulties and dangers; and do Thou, Great Father, keep us and them.

“May they be enabled now and always to strive on in faith and hope and love, looking for future progress in the knowledge of Truth.

“DOCTOR.”

“The days come when the Adversaries shall be abroad among the Children of the Light. Heed ye, and be wary, and prayerful and watchful. Keep yourselves separate from the snares of the Adversaries.

“The Warning of PRUDENS, DOCT., Minister.”

“This is the most wonderful piece of direct spirit-writing that was ever given to us, or that we had ever seen.”

Another question exercised Mr. Stainton Moses. About the year 1850, the doctrines of pre-existence and “Re-incarnation” were rather popular in France. M. Pezzani, in his work, *The Plurality of Existences*, gives a list of the works that had appeared on the subject, before it was taken up by the “Spiritists.”

A little before this time, a gentleman named Roustan, experimented with a mesmeric sensitive, who had been frequently treated previously for a complaint that had confined her to her bed for twenty-seven months. Her professional name was Madame Japhet. Mons. Roustan was very warm on the doctrine of Re-incarnation. Soon Madame Japhet, in her lucid state, confirmed him in this theory. She was assisted by St. Theresa and other spirits.

Soon a circle was formed to study this interesting topic. M. Victorien Sardon was one of the investigators. M. Allan Kardec, then known as Hippolyte Léon Denizard Rivail, was another. This gentleman became possessed of a mass of MSS., in which the communications of Madame Japhet were recorded. He worked them up into a volume, entitled *Le Livre des Esprits*, but, studiously kept the name of Madame Japhet out of it. To inquirers it was given out that she was dead. His work was published in 1856.

In 1873, a Russian gentleman, named Aksakof, came to Paris. He was much interested in Psychic studies. To his astonishment he discovered that Madame Japhet was not dead. Soon he was introduced to her, and learned the genesis of *Le Livre des Esprits* from her own lips. M. Allan Kardec had never even sent her a copy of it. More than that, he had refused to give up her MSS. “Let her go to law with me,” he said. Mons. Aksakof has recorded all this in the *London Spiritualist* of 1875; and

also that the mesmeric influence of M. Roustan over Madame Japhet remained so strong, that after all these years she could still throw herself into the lucid state by the aid of objects that he formerly had magnetised.

What is Allan Kardec's theory?

God, to spiritualise the individual, sends him into the earth life time after time. At death he is *errant*, a wanderer. He reflects on his past life, and repents bitterly. Then "Providence" (*Qu'est ce que le Spiritisme?* p. 75) settles that his time has come for another rebirth. The individual is allowed to choose what he will be. Then he once more enters a mother's womb, and oblivion of the past comes over him. This process is repeated until he becomes a *pur esprit*, a permanent *errant*, wandering about in vague spirit spheres. The blots of this system are on the surface, and they become more plain when we see it in action. In *Le Ciel et l'Enfer* of Allan Kardec, a spirit communicates, one Joseph Maitre (p. 492), who went blind at thirty years of age, blasphemed God, and committed suicide. In the next world all was darkness, but he knew that his effort to plunge into nothingness had failed. A certain time elapsed, and his agony and remorse were unbounded. Then bright spirits came to him, and he saw the celestial revealings (*les célestes clartés*.)

Now it is plain from this narrative, that all the spiritualising influences of Joseph Maitre came to him during his sojourn in the spirit world. On earth he was "acariâtre exigeant, insupportable," indulging in "des excès de tous genres." He was guilty of blasphemy and suicide. And yet in a few months the old Adam had departed and he was regenerated.

Now the question at once suggests itself, why should poor Joseph Maitre, after having reached these pure altitudes, be plunged once again into Paris life and its "excès de tous genres"? Having interior knowledge greater than Boehme, and a mind more exalted than General Gordon, why should all this be swept away?

"Oh!" it will be answered, "the new Joseph Maitre will be quite different from the old one. He is now semi-angelic. No *excès de tous genres* in his Paris life now!"

This brings theory a little into the domain of experience. The Parisian contemporaries of Joseph Maitre were, as a body, no worse—in fact, rather better—than him. They, too, must have gone through the same purifying processes in the spirit world. They, too, have all come back to Paris. Do we see the complete elimination of the *excès de tous genres* in these semi-angelic citizens?

Another point: guided by modern science, we guess the existence of God from His large laws; but “special Providences,” as they used to be called, are discredited. But in M. Allan Kardec’s scheme this “Providence” is constantly appearing and settling the many re-births of each of us. He no longer rules by large eternal laws.

Another point is, that man may choose what he will be in his next earth life. Of course ninety-nine spirits in a hundred would say, “Let me be the Czar of Russia, or Jay Gould.” Here, again, we have the test of experience. “Spirits never deteriorate,” says Allan Kardec. This is also against human experience.

Certain of the “perfected spirits” sometimes incarnate as Messiahs. Why this, if earth life is the great spiritual teacher?

Mr. Stainton Moses from the first opposed these theories. He said, Why should a man try earth life a second time when his first visit had proved a failure? He said, too, that a mesmeric sensitive was not to be relied on. The operator only got back his own ideas.

## CHAPTER VIII.

VADE RETRO SATANA!

IN Mr. Stead's interesting New Year's number, entitled *More Ghost Stories*, we read—

### “THE SEAMY SIDE OF SPIRITUALISM

“There is little difference of opinion, even among the better class of the spiritualists themselves, as to the moral and physical degradation which overtakes most professional mediums. A system cannot be defended which wrecks the moral and physical health of its votaries. The phenomena of trance which are to be witnessed at the séance when the medium professes to be taken possession of by any intelligence are not such as to commend them to any prudent man or woman who has any respect for his individuality. When in the trance, as it is technically called, women who cannot bear the smell of tobacco will smoke a pipe as eagerly as an inveterate smoker, and teetotalers will drink whisky as eagerly as if they were habitual drunkards. In automatic writing, which is one of the simplest forms of spiritualist manifestations, it is a record that young girls of unimpeachable character have been made the agent for producing writing and drawing pictures the very nature of which they were fortunately unable to understand. There is no necessity for going further into this subject beyond a general statement that at some séances, whether through the influence of self-hypnotism, or through the presence of invisible agencies, sitters have had experiences which may be purely subjective, and have no objective reality, but are not the less degrading and abominable. To expose yourself to all the chances of such things may be justifiable if out of the midst of all

these temptations and suggestions to mental and moral disease you have a tolerable certainty of being able to gain any counterbalancing advantage. But, so far as I can see, the chances for the ordinary man or woman are too slender. This tree of the knowledge of good and evil seems to bear so much more evil than good, that Eve had better stay her hand."

Now all this is in the highest degree important. Does Mr. Stanton Moses confirm Mr. Stead?

In answer to this I must announce that over and over again he has told me that his mediumship passed through one very grave crisis indeed. Evil spirits assailed him. His days were perturbation and his nights were terror. He saw these spirits. He heard their voices. Every sense was assailed. The foulest stenches spread through his bedroom. He tried the Indian Yoga, so far as to give up fleshmeat and wine. This only made matters worse.

Now all this is very grave. Mr. Stainton Moses, in point of fact, had reached that dread portal that all mystics, all schools of magic, all religions, speak of under many symbols. What are the grinning demons, the gurgoyles at the Western gate of a Gothic Cathedral? What are the strange monsters at the gate of a Buddhist temple? In the middle ages why did the students read the mass book backwards and burlesque the Christian rites? What is the meaning of the darkness and too real biting and fighting just before the Pontiff at Jerusalem goes into the Holy Sepulchre and brings out the miraculous fire? All these things typified the demoniac hauntings of Christ, of Buddha, of St. Anthony, of St. Jerome, of Madame Guyon, of Luther. Even the rough fooling of some lodges before the mason reaches the Royal Arch had once a similar meaning.

To an earnest clergyman all this created terrible doubts. Often and often Mr. Stainton Moses thought his "guides" devils from hell.

Ever since the famous American "rappings," alarmed Orthodoxy has flooded the literature of the period with its warnings. Priests, clergymen, laymen, have pointed out the manifest "Satanic agency" in the movement. Let us listen to Father Clarke, of the Order of Jesus, the

most able of these expositors. His little work is entitled *Spiritualism: its Character and Results*.

We therefore arrive on the ground of the doctrines taught by the spirits at the same conclusion at which we have already arrived above, that the spirits who are present at Spiritualistic séances and hold intercourse with mediums, by whatever means it be, are simply devils from hell, pretending to be the spirits of the dead, and using their preternatural knowledge and power to deceive men.

"The writer quotes Deut. xviii. 9-12, where the Jews are warned against certain abominations practised by the nations of Palestine. Among other abominations that of 'seeking the truth from the dead' is mentioned—that is, of practising the art of necromancy, which, says Father Clarke, is the 'essential feature of Spiritualism':—

"Now, if these practices were specially forbidden to the Jews as being God's chosen people, if they were merely unlawful by reason of Divine or ecclesiastical enactment, they would not be brought forward as the reason why the heathen nations were dispossessed. God would not have punished the heathen for any except crimes against the natural law. To seek the truth from the dead is accordingly an offence against right reason, and cannot be excused even in a Pagan nation.

"The spirits who appear to those on earth, when invoked by them, are not what they profess to be, nor the spirits of departed friends, but the ministers of Satan who assume the character and even the appearance of the deceased, and manifest secrets known only to them, in order to deceive the living and bring them into their power. All commerce with them is therefore a direct dealing with Satan and the devils who serve him."

But this raises rather a large question. We have seen from Renan that the first Christian Church, the Church of Jerusalem, was a little society of *illuminati*. All were, like Madame Guyon and the Père la Combe, psychics. "Desire spiritual gifts," says St. Paul, "that ye may prophesy." And in the previous chapter (1 Cor. xiii.) we can see what he means by spiritual gifts. These are the word of *Sophia* and the word of *gnosis*, two words always

used to denote what Madame Guyon calls "interior knowledge."

Another spiritual gift is the "gift of healing," that is mesmeric healing power similar to that of the Père la Combe and the Curé d'Ars. Going through St. Paul's catalogue we find "prophecy," the power of "working miracles," the power of speaking in unknown "tongues." Last of all comes that psychic state possessed so eminently by Swedenborg, in which the denizens of the spirit world become manifest. St. Paul calls it the "discerning of spirits" (1 Cor. xii. 10). St. Mark confirms St. Paul.

"And these signs shall follow them that believe: In my name shall they cast out devils. They shall speak with new tongues. They shall take up serpents; and if they drink any deadly thing, it shall not hurt them. They shall lay hands on the sick, and they shall recover" (Mark xvi. 17, 18).

Thus the "Catholic" Church, when it came fresh from Christ, far from forbidding these practices which Father Clarke considers "demoniac," held no one to be a Christian who did not practise them. The lay element of the church, the "Catachumens," as distinguished from the Mystagogues, came in much later. And our study of the life of Madame Guyon carries us a step further.

Plainly the Catholic Church is in essence an apparatus of magic. No one can go straight to heaven but monks or nuns who have exhibited miraculous gifts in their earth life. All are enjoined to practise "Contemplation," which I have shown is magical training. The "Spiritual exercises" of Loyola are used by half Christendom to this very day. And laymen are made still to go through the farce of a week's practice of them in Lent, as in the days of Louis XIV. laymen, say Mons. Jourdain and Madame Jourdain, and that lady's sparkling tempter the Marquis, were made to go through a similar comedy. The old "mysteries" were schools of magic; and Bishop Warburton, in his *Divine Legation of Moses*, has shown that with the Christian Fathers the Christian mysteries were called "Orgies," "teletas," "epopteras," just like the pagan ones. The priest was "Mystes" "Hierotelestes," "Mystagogon."



And is it not a little quaint that with Jesus and Mary as the centres of Catholic worship, Father Clarke is so shocked at the "abominations" of "seeking truth from the dead"? Also, if he has never heard of the saints being actually worshipped by Catholics, he has plainly never travelled in Italy or Spain. Another question: What about Black Magic? The "Spiritual exercises" of Loyola, by inciting the pupil to try to picture "with the five senses of the imagination" Hell and Satan, go very near materialising or raising the devil. Certainly the official Church Anathema, given by Mr. Shandy, is not to be distinguished from the Dharna of Indian witches.

"May all the angels, archangels, and principalities and powers curse him. May all the saints who from the beginning of the world to everlasting ages are found to be beloved of God damn him. May he be cursed in living and dying. May he be cursed in eating and drinking, in being hungry and thirsty, in slumbering, in waking, in walking and standing, etc. May he be cursed in the hair of his head, in his brains, in his temples, his forehead, in his ears, in his jaw bones, in his fore teeth and grinders."

And Father Clarke must remember that the Father Clarkes of the day have not been always very certain of the origin of even Catholic miracles. St. Theresa has been canonised, but we see from her life that such experiences as she had, raptures in prayer, levitation, and the opening of her interior senses to sights and sounds only accessible to them, were not in her day understood. "It once happened that many people met together in whom I placed great confidence. They consulted with one another about finding a remedy for my soul, for they loved me much and feared I might be deceived. I think there were five or six, all of them great servants of God. But my confessor told me they were all firmly convinced that my prayer came from the devil, and they advised me not to communicate so often" (p. 215). "People were so certain that I was under the influence of the devil that they wished me to be exorcised" (p. 253). "As my visions began to increase, one of those who used to hear my confessions when my ordinary confessor was not in the way told me that I was evidently deluded by the

devil. He commanded me, since there was no better means, always to be crossing and blessing myself when I saw any vision, and to use some sign of scorn, because it was certainly the devil.

"This command was very painful to me, as I could not help believing that my prayer came from God. It was a terrible thing to me to use any act of scorn, neither could I desire that these things should be taken from me; still I did all that was commanded me" (p. 253). "When he spoke in this manner to me great was my affliction, and many the tears I shed, through the fear that I had, for I certainly desired to serve and please God, and I could not persuade myself that this came from the devil" (p. 197).

At last her own convictions overpowered those of her devout advisers, and she wrote: "As for believing that these favours come from the devil, it is not in my power to force myself into such an opinion." Though with her usual sagacity she observes, "However, the devil knows how to play many tricks, and therefore, in this matter nothing is so certain but that something may still be feared from him."

But Mr. Stainton Moses was a Protestant, a clergyman of the Church of England; and the Protestant mode of viewing spiritual intercourse differs in some points from the Roman Catholic. The Reformation, as Macaulay announces, was the revolt of the layman against the monk; therefore at once all convents, monasteries, monks, nuns, were swept away. The layman's religion alone survived, the religion of the old Catechumen. The interior knowledge, the "Gnosis," with him was to be derived alone from the perusal of a book, or rather a number of conflicting books, and an article in the new "Encyclopædia Britannica" (*sub voce* Gnosis) quaintly recommends the same method of attaining it. It was held that "miracles" had been permitted up to the date of the death of the last apostle, and that then they ceased. Their object was to "prove" that the Old and the New Testaments were both written by "the finger of the Almighty." Side by side with the Jewish miracles it is admitted that pagan miracles are everywhere to be

found, but every marvel not performed by a Jew was due to the devil.

But here a difficulty arises. Many of the most conspicuous "Prophets" of the chosen race were prophets, not because they were born Jews, but because they had been educated in Gentile schools of supernaturalism. Abraham is an example. Joseph was head soothsayer to the King of Egypt, and divined with an Egyptian divining cup of the pattern we now see in museums. Moses was an Egyptian initiate; and to be able to marry the daughter of a priest of Midian, he must, it is urged, have been admitted into the Phœnician hierarchy likewise. Balaam was a Gentile, a prophet of the Midianites, and yet it is recorded that "God" spake through him (Num. xxii. 8). The witch of Endor was also a Gentile prophetess whose life was threatened by the Jews, and yet the Prophet Samuel made use of her to come back to earth. Daniel was *Rab Mag*, the actual head of the Babylonian Magi.

This brings us once more to the bad spirits that annoy all who try to emerge from the state "that is spiritually called Sodom and Egypt."

"Avoid the grinning Gurgoyles altogether!" Thus counsel our bishops.

That is all very well. There was an old lady who said, "I will have nothing to do with these new-fangled germs." But the question of course is, Will the new-fangled germs have nothing to do with us?

A wise physician refuses to prescribe until he has probed the malady. To experimental occultism we owe a debt of gratitude. It has probed the malady.

Instead of Milton's Satan and a well-drilled army of spirits, wise, unselfish, almost omnipotent, it has disclosed a disorderly mob, the dead of yesterday, selfish, brutal, besotted—in fact, unchanged. These desire to live over again their gross lives, to frequent the old haunts of iniquity, and it is to please themselves, and not to damn our souls, that they befoul our minds. The "great law of Association," as "Imperator" puts it, holds good in all worlds. Dead misers prompt living misers. Dead courtiers prompt living courtiers. Dead beauties still dream

---

of conquests and jewels. Dead prelates still dream of partisan watch cries. We are "semi-corpses" as Boehme has told us, "Porkers of Satan"; and the advice given to us to remain "semi-corpses" is scarcely sound, even if it comes from an archbishop.

"But we avoid the disorderly spirits that vexed Mr. Stainton Moses."

That is true. It is when the "Porkers of Satan" try to leave their garbage that they get the prods and the cudgelling. At least, that is what Boehme tells us.

## CHAPTER IX.

### MADAME BLAVATSKY

AT some length we must now digress to talk of a very celebrated lady.

In 1876, Madame Blavatsky founded the Theosophical Society, and Mr. Stanton Moses was an original member of it. This will appear strange, because in a letter to the *Pall Mall Gazette* of April 26th, 1884, the Russian lady announced that the main object of the Society was to put down Spiritualism.

Mademoiselle Hahn was born in the South of Russia in the year 1831. At the age of seventeen she married Gen. Blavatsky, whom she promptly left. In the month of September, 1856, it is alleged that she went to Tibet, and remained there about six months. There she learned the secrets of Eastern occultism from one Koot Hoomi Lal Singh, the oversetting of Spiritualism being, as I have said, one of his objects in teaching her.

How, then, did Mr. Stanton Moses become a member of the Theosophical Society? For the simple reason that it was announced to be a spiritualistic Society. The first paper read before it went to show that in Ancient Egypt communion with the dead was "reduced to a positive science." This paper was read by a Mr. Felt "in the parlours of Madame Blavatsky." Colonel Olcott, in the *Banner of Light*, announced that "Occultism does not rob Spiritualism of one of its comforting features." Moreover, Madame Blavatsky had figured as a professional medium in Cairo, and apparently also in Russia. In America also she was prominent at séances, and announced that she had detected her dead father, at one of them, and that he had brought from the tomb the buckle of his medal of honour. Certainly at this time the dangers that result

to Spiritualists from "Shells" and "Elementaries" did not seem to disturb her much. Mr. Stanton Moses enrolled his name, and entered into a long correspondence with the Russian lady.

Like all the old mysteries, Theosophy is the quest of "Perfection." Its main teachings may be briefly set forth. It proclaims that at death the individual becomes practically two individuals; one of which takes off all the good qualities to the "rosy slumber" of Devachan or Paradise. The second, with all the bad qualities, remains on the earth plane for a time, attends séances, deceives Spiritualists, and is by-and-by annihilated. The only communications that mortals can receive from the unseen worlds are from these semi-fiends.

To this has been added the Indian doctrine of Karma. It is proclaimed that the good half of the individual must remain in Devachan for 1600 years. It is then reborn on earth; and Karma, or the causation of its previous acts, will force this process to be repeated "at least 800 times." Then Perfection will be gained, and with it annihilation.

It will be seen at once that we have here two distinct schemes for gaining perfection.

By the first, perfection, even with a murderer like Dr. Neill Cream, is obtained at the second of death—a perfection greater than that of the angel Gabriel, for the smallest blemish will be removed. By the second, even St. Paul will be 1,280,000 years obtaining perfection.

Sceptical critics have thought that they detected in this an attempt to mingle Eastern and Western occultism. Some illogical person, they contend (whether the name be Blavatsky or Koot Hoom is of little moment), has given a not very well digested version of the Indian Karma idea. The same person has copied down almost verbatim the teachings of a French Abbé, who wrote under the pseudonym of *Élephas Lévi*. This gentleman was a Kabbalist, and he professed to discover this doctrine of the division of the individual at death into a bad and a good half in the Kabbalah, and also the doctrine that only the fiendish half can communicate with mortals. This is a quaint statement, as the Kabba-

lah professes to be derived from the ghosts of Abraham, Moses, Jacob, etc.

In 1883, I suddenly came across Mr. Stainton Moses in Jermyn Street, close to St. James's Church.

"Have you heard the news?" he said excitedly.

"No!"

"The Blavatsky bubble has burst."

"Tell me—tell me."

"A Professor Kiddle has written from New York to *Light*, pointing out that one of the letters purporting to have been written by Koot Hoomi from Tibet, is a long and almost verbatim plagiarism from a lecture of the Professor's that was published in an American newspaper called the *Banner of Light*"

This discovery created an immense excitement in occult circles. And an explanatory letter from Tibet, if anything, made matters worse. In it Koot Hoomi announced that he had gone off to Lake Pleasant in his astral or spirit body, and there had heard Professor Kiddle's inspirational address.

"For the first time in my life I paid serious attention to the utterances of the poetical media (American for mediums), of the so-called 'inspirational' oratory of the English-American lecturers, its quality and limitations. I was struck with all this brilliant but empty verbiage, and recognised for the first time fully its materialism."

Returning to the flesh in Tibet, with this "inspirational" discourse jingling in his ear, the Mahatma proposed not to plagiarise from it, but to attack it in a letter sent to Madame Blavatsky through the spiritual telegraph. "Proofs," it appears, are struck off in this process, but the Mahatma being tired after a long ride, failed to correct them on this occasion. These "proofs" are all carefully kept; and a new version of the letter corrected from the proofs was sent.

But the terrible Professor Kiddle was again on the watch. In *Light* (September 20th, 1884), he pointed out that if the Mahatma went in his astral body to Lake Pleasant he could scarcely have heard the discourse, for it was delivered at Mount Pleasant.

Also, if the main object of his astral flight was to

witness a "medium" discoursing under the obsession of a spirit, it is difficult to understand his satisfaction at his success, for the Professor is no "medium," and he read the lecture from a manuscript.

The result of all this was that Mr. Stainton Moses left the Theosophical Society, with Mr. Massey and Mr. Percival. Dr. Anna Kingsford, the President of the London Lodge, seceded likewise with Mr. Maitland. These two had, already protested in a joint pamphlet against the blank atheism which they believed to be preached.

But although Mr Stainton Moses retired, oddly enough he took the side of Madame Blavatsky on the occasion of a much more important *exposé*, when the *Times* published the letters of that lady to Madame Coulomb. His mind was singularly just, and he maintained to me that we had no right to give any credit to so tainted a witness. But he said he had never for a moment believed in the Mahatmas. The statements of Madame Blavatsky concerning them had been much too contradictory. She first announced that they resided in Malta.

When the Coulomb letters appeared, Theosophy seemed lost. In point of fact there was only one being in Europe that could restore it.

Mrs. Besant possessed a number of qualities that Madame Blavatsky lacked. Instead of speaking broken English she was a master of good Saxon, and she was singularly eloquent both in attack and reply on the platform. Also, in an age of shams she was most truthful. And in one cruel moment, when the paths of strict honesty and of electroplated piety diverged, and she was called upon to make her choice, with her little infant the mother went out into the cold night, not knowing when she could give that infant another meal. Action produces reaction, and it seemed at one time that Mrs. Besant rather courted unpopular causes, having, perhaps, nicely gauged the value of popular approbation. She wrote Ramsgate pamphlets, Socialistic pamphlets, and pamphlets on other topics less popular still. She found Theosophy in the middle of a shipwreck, and she has saved it; but



only, I fear, by the time-honoured process of throwing the great prophet into the sea.

Thus Madame Blavatsky proclaimed that God was "unconscious" (*Esoteric Buddhism*, p. 176). Mrs. Besant's God, though veiled in Boehme's *Ungrund*, is in possession of his faculties. Madame Blavatsky announced that private occultism was most dangerous on account of the "Shells," and that we must take all our knowledge of the unseen world from the dogmatic utterances of a mortal in Tibet. Mrs. Besant holds that to bridge the two worlds is the main duty of man. Madame Blavatsky proposed to spread Theosophy by magic cups and brooches. Mrs. Besant announces that no outside evidence can appeal to the interior man. And she seems to have carried the main body of the Theosophists with her in her change. At one bound they have sprung from Blavatsky to Boehme.

One proof of this is the anger that the new school show at the doctrine of "shells." They say it is a gross libel to announce that Madame Blavatsky ever affirmed that a mortal at death became two sentient beings, one taking all that was good in his composition, and the other all that was bad. But in *The Theosophist* of October, 1881, this is very clearly stated by the Russian lady herself. "At death, or before," she says, the "spirit," the higher ego, "becomes a new person," that "can never span the abyss that separates its state from ours." Here we have plainly one sentient being, who has carried away with it all that is good.

She announces also that the so-called "Spirits of the departed" of the séance room are nothing but the "reliquiae" of deceased human beings, the bad halves of mortals. "All that can appear are the shells of the deceased." She announces, further, that these fiendish creatures sometimes give vent to "really lofty ideas," but only for the purpose of deceiving the elect. But here it is plain that, whether we call him a "relic" or a "spirit," a sentient being capable of coming all the way to a séance room, and uttering "really lofty ideas," is a distinct second person.

That this world is inspired from the spirit world by

fiends alone is of course a preposterous doctrine; and Mrs. Besant has done wisely (*Death and After*, p. 70) in announcing, in the teeth of Koot Hoomi, that the good halves of mortals can influence us as well as the evil ones. But if she feels justified in throwing overboard a part of his teachings, why not throw over the most immoral part? At death, as we have seen, the individual becomes two individuals. The first of these goes off to a paradise called Devachan, taking all the good qualities. The second remains on earth, taking all the evil qualities. The fear of its consequences is what mainly deters man from an evil act, but by this silly theory this wholesome fear is removed. Dr. Niell Cream, the murderer, two seconds after his execution reached Devachan, so we must suppose, in a state of moral purity exceeding that of the angel Gabriel, for all moral evil would have walked away from him. Besides, the idea of dividing the *individuum* (that which cannot be divided) into two individuals is nonsense. He has, roughly speaking, a memory, a volition, a mind, a conscience, a non-atomic body concealed within a visible form. The idea of two memories, two volitions, two minds, two consciences, two non-atomic bodies belonging to one individual is too absurd.

I think, too, that Mrs. Besant has been injudicious in repeating in her work, *Death and After*, Madame Blavatsky's Seven Principles.

They are:—

1. The Body (Rupá).
2. Vitality (Jiṣa)
3. Astral Body (Linga Sharira).
4. Animal Soul (Kama rupa).
5. Human Soul (Manas).
6. Spiritual Soul (Buddhi).
7. Spirit (Atma).

Now if we examine the most approved Theosophical explanations of these "principles," what do we find? A confused jumble of two totally distinct ideas. At starting, Madame Blavatsky seemed to have meant by the word "principle," what Dr. Johnson means—principle—from *principium*—that which is from the beginning—primordial substance. But the good Russian lady, whose

mind was too quick to be logical, seems to have forgotten all this before she had done, and writing "currente calamo" to have changed her seven principles into seven states of spiritual progress. Of number seven she thus writes in the first draft, (*Theosophist*, October, 1881), "The Spirit—an emanation from the Absolute, uncreated, eternal, a state rather than a being" This, according to strict laws of English, means nothing at all. How can a "state" be an "emanation"? Madame Blavatsky probably meant that after many years—thousands and thousands, according to occult teaching—a man may become of such lofty spirituality as to be one with God, a Being who had not apparently been dethroned and rendered "unconscious" by the Mahatmas, when her article was written. But how can a state that a man reaches in a million years be called a "principle"? This confusion of thought is also conspicuous in *Esoteric Buddhism*. The sixth principle is "not in us," but said to be "hovering over us" (p. 26.) We learn, too, that the "higher principles" are not "fully developed at first." This would, however, make no difference to a man, for if the sixth principle is not to be in him until after at least 800 re-births, it does not signify much where it is hovering. But this confusion becomes worse confounded when we deal with the fifth principle, "manas." Mr. Sinnett tries to make that also a state of spirituality. He calls it "human soul," and says that in the "majority of mankind" it will be long before it develops. It is a "portion of this principle" (the language gets quainter and quainter) which, commonly called the astral body, is sometimes projected to a distance by an adept. Manas is simply the Sanskrit word for the intellect, and up to this point the original conception of the Russian lady seems to have been intelligibly carried out. To make this a state of the soul that the majority of men cannot hope to grasp until they become "fifth rounders," and what not, is certainly far from rational. But in Mr. Sinnett's favour it must be said that he had to make some sort of sense of the following definition of the fifth principle (*Theosophist*, October, 1881): "The physical intelligence, or consciousness, or Ego, analogous to, al-

though proportionately higher in degree, than the reason, instinct, memory, imagination, etc., of the higher animals." In a work published by Messrs. Trubner, in matter of fact *Ludgate Hill*, a trained writer could not well talk about a "physical" imagination. But if these are Kabalistic words that have come from Mahatmas, do we gain as Occultists by Mr. Sinnett's substitutions?

Of the lower principles I need not say much. I must, however, point out one quaint slip. The Western mind, knowing nothing of the metempsychosis, has a very vague idea about what the Hindoos mean by the "linga sharira." A Westerner knows that he has from his mother an atomic body (*rupa*) at starting, and he hopes to get, but is little doubtful about it, a glorious body (*linga sharira*) at the resurrection. With the Hindoo this order is reversed. The "linga sharira" is the perpetual envelope of the soul. "It is primeval," says Colebrooke in his analysis of the Sankhya philosophy (*Essays*, vol. i., p. 245), "transmigrating through successive bodies, which it assumes as a mimic shifts his disguises to represent various characters."

Now it is very plain that both Mr. Sinnett and Madame Blavatsky, misled by early Western teaching, have quite failed to grasp this. The Russian lady meets, let us say, Koot Hoomi Lal Singh. She pronounces that he has "rupa," an atomic body, and "linga sharira," and that these are "principles," things that have existed from the beginning. But if Koot Hoomi Lal Singh has been on earth "at least 800 times," with a gap of 1,600 years between each rebirth, his *rupa*, far from having been with him *a principio*, will have come into existence 1,280,000 years after his "linga sharira."

There is another point. When the Koot Hoomi myth was exploded, some Theosophists, giving that up, still held that the seven principles embodied the "Esoteric Eastern Teaching," and that they had been derived from a real Indian student of Yoga, named Subha Rao. But in his work, *Discourses on the Bhagavat Gita* (page 5), that gentleman has repudiated this. He says that the stages of spiritual growth in India are four not seven, the four Upadhis. Any student of real Indian works might have known this.

A word about the metempsychosis which Mrs. Besant is so enthusiastic about.

For years I have been a patient student of the real Indian Theosophy, and I think that the old Indian books are destined, at no distant date, to breathe life once more into the dead theologies of Europe. But before we attempt building it is necessary to get the ground firm under foot. Buddhism, or Gnosticism, whether held by Ananda, St. Paul, or Mirza the Sufi, is the most purely spiritual religion yet given to man. The word simply means knowledge of spirit. Buddha, as he sat under his *figus religiosa* at Buddha Gaya, threw overboard all the theories of the spirit world that can be taught by mortals. His religion was not a guide-book, but a vehicle to carry you to the country. It follows from this that all outside theories such as the metempsychosis are extraneous. They may be true, but they are not Buddhism.

And I must say at once that I never had any great enthusiasm for this theory. In early Vedic days the Hindoo had a creed very like modern Spiritualism. He knew from his Rishis that the dead lived once more, in a region more happy than earth. And, by-and-by, for the purpose of amelioration, the Rishis tacked on to this region of delight a region of punishment. This religion of the Rishis had two advantages over more recent theories. The punishment was corrective, which means that it was not eternal. And the prickings of conscience were the main corrective agent, for man remembered his evil deeds. Then came the metempsychosis, which is based on two errors, one physical, and the other psychical. Old astronomers taught that the world was a very, very large place, and that the stars were small lamps fixed on to a solid dome of limited size. Thus, when man in fertile India began to increase and multiply, the question arose—where will the vast armies of the dead find a place? In their ignorance of spiritual law they were not aware that two, twenty, fifty, a billion of groups of spirits might reside on the same planet, and that the walls, prisons, rattle, of one group might only affect that particular group, and that the members of the other groups could step through these walls as easily as

Quintus Curtius jumped into the chasm to save the State. At Eton perhaps he gave his cake to a young honourable, not altogether because he was an honourable. A man cannot be an attorney or a Barnes Newcome all at once. What does this mean? Simply that the life of a Barnes Newcome is pure deterioration. Supposing that from the womb of Lady Newcome he obtained his fiftieth re-birth, it is quite plain that his fifty-first would carry him lower down in the scale. He would be saddled with all the infamy that we know so well. And if his fifty-first life was worse than the fiftieth, what would the hundred and fifty-first be like? If Theosophy be true, Barnes Newcome would plainly go down and down into a never-ending abyss with accelerating momentum.

The Brahmin priest and the Buddhist monk are wiser in their generation, for they say that an offering of flowers, or five hundred revolutions of a prayer-wheel, would get Barnes Newcome a fund of good Karma from Rama or Buddha, which would modify his evil Karma.

Let us apply what we may call Swedenborg's test to Mrs. Besant's system. In this world memory and remorse form the two teachers that guide us. This memory and remorse cannot be split in half, cannot be transferred to a second individual, the crop of results being kept strictly to the sower of the seed. Nobody resides in the "Rosy slumber of Devachan," as Mr. Sinnett puts it. Would Mrs. Besant, the ever active, like that "rosy" but ignoble inactivity? In this world the strong minister to the weak, and transfer their experiences, as in Swedenborg's system. With him the two worlds are harmonious, and one mighty law of evolution and heredity improves the race *en bloc*. In Theosophy, though it talks of evolution, all is inconsequence, all is arbitrary. Besides, what is there in the strict law of cause and effect that a lady who steals a brooch at the Stores should in her next life have her neck wrung as a thieving fox, or a leader of Calabrian bandits? In point of fact, the early Buddhist Sutras make Indra settle these matters, not "Karma," or cause and effect. All absurdities had once a logic.

## CHAPTER X.

### EXPLANATIONS.

MR. STAINTON MOSES had now time to sort his strange experiences, and to guess their meaning. The problem was crucial. It was the problem of religions, the problem of priests, the problem of men of science. Ever since man has looked up at night into the sky, he has tried to guess what was behind the darkness. To our young clergyman a number of most bewildering phenomena had been presented. And the explanations of these phenomena by various sections of the students of occultism were more bewildering still. We will sketch out a few of these explanations.

Let us begin with a puzzling phenomenon,—a ghost.

The great Lord Brougham, in his diary of his Swedish travel, writes thus:—

“After I left the high school I went with G——, my most intimate friend, to attend the classes in the university. There was no divinity class; but we frequently, in our walks, discussed and speculated upon many grave subjects—among others, on the immortality of the soul, and on the future state. This question, and the possibility, [I will not say of ghosts walking, but] of the dead appearing to the living, were subjects of much speculation; and we actually committed the folly of drawing up an agreement with our blood, to the effect that whichever of us died the first should appear to the other.”

Lord Brougham goes on to say that G—— went to India, in the civil service, and that many years afterwards, when he had almost forgotten him, he put up for the night in an inn near Gottenborg. Being very cold he took a warm bath, placing his clothes on a chair. Looking up, on the chair sat G——, looking calmly at me. How I

got out of the bath I know not; but on recovering my senses I found myself sprawling on the floor."

Lord Brougham wrote down the date, the 19th December, and in due course of time came a letter from India, announcing that on that very day G—— had died.

How is this phenomenon to be explained? A dozen answers are suggested. Let us begin with pure science. The argument of the disciples of Buchner and Professor Clifford is something after this fashion:—

"Imagine a cricket ball struck by Mr. Stoddart. It runs along the grass. Here we have matter and force. It stops. Where is now the force? Plainly it cannot be hovering about, apart from the cricket ball. It is non-existent. The matter alone remains. This means that the force is not cognisable without the matter. Imagine the universe a large cricket ball, matter and force once more. The theologians call the force God. Again, it is impossible to imagine the force without the cricket ball. That the force created the cricket ball is an absurdity. Man is a smaller cricket ball. He has in his brain a grey cerebral substance, which he calls "thought," "soul." But a rabbit also has this grey substance, this "thought," this "soul." And the surgeon's art has been able to remove almost the whole of it from a rabbit's skull, and the rabbit, without volition, without soul, and in a semi-lethargic state, has lived for a long time, and, artificially fed, has even grown fat. If we are asked whether the ghost G—— was the real G——, we answer that he became non-existent when the cricket ball stopped.

On the other hand, the apostles of Psychological Research have a different theory: G—— appeared not at the moment of death, but a quarter of an hour before. It was a "Phantasm of the Living." Then, again, Mr. Herbert Burrows, the President of the Theosophical Society, would say that G—— was a "Vampire," and Mrs. Besant would call it a "Shell," the bad half a Bengal Civil Servant, whose good half had gone to Devachan and its "rosy slumbers."

A second ghost story I heard from the lips of Mr. Stainton Moses himself. A French professor named Cassal died; and about a week afterwards, Mr. Stainton Moses, in a new gown, was walking along one of the



corridors of the university school. Suddenly he felt his gown plucked from behind, and as the masters at the time were making merry over its introduction, he thought that one of them was playing a prank. Turning round he saw Mons. Cassal. A few minutes afterwards Mr. Stainton Moses returned to the same spot in the corridor, being uncertain in his mind, whether or not he had dreamt the whole thing. He came to that spot for verification. Nothing occurred, but in quite another part of the passage his gown was again plucked, and again he saw his dead friend.

Here pure science would repeat the same story, and Blavatsky "Buddhism" would talk of "shells." But Psychic Research would be more puzzled. This ghost could not have come a quarter of an hour before his death, for Mr. Stainton Moses had been to his funeral. This Society has taken the trouble to collect at first hand several dozen ghost stories, and they hold that every ghost was alive, and not dead, at the moment of the appearance. Thus a Mrs. Sherman, of Muskegon, Michigan, on the 4th July, 1868, saw her brother Stewart at the exact moment that after intelligence showed that he had died. "A Phantasm of the Living this!" say the editors; but they puzzle us with a further announcement. The lady by-and-by managed to go to sleep, and again the phantom came and woke her by pulling the sheet off her neck. Was this a phantasm of the living? Then a Mrs. Lightfoot, on seeing her dead friend Mrs. Reed, had the words "She is dead!" "simply burnt into her mind." If the ghost were still living, why should he select these words to burn into her mind?

We come to a more complicated phenomenon.

An interesting paper by Mr. Myers, in the *Proceedings of the Society for Psychical Research* (vol. iv), shows how two undergraduates, named Schuller, and their sister, made experiments with a planchette. Many "spirits" came with *soi disant* names, "Irktomar," "Lokendranath," "Eudora," "Johnson." They wrote sometimes in languages that the mediums did not know. "Irktomar" wrote the following: "Carles li reis magnes empere set auz lutins estet en Espagne."

The mediums thought this gibberish; but it turned out to be a quotation from the *Chanson de Roland*, with only two slight errors in it.

"Lokendranâth" ("Lord of the heavens of India," in Sanskrit), on being asked whether he was a Mussulman, replied thus: "Hindi ap ka hai."

This is nonsense, and so is the translation given in the *Proceedings*. But if we substitute jât for ap, it makes a sensible answer. "He is of the Hindoo's Creed—"

Mr. Myers gives his explanation of these facts. That "Irktomar" and "Johnson" are real spirits is of course a preposterous idea. It would be "in the last degree lamentable" if spirits could return for "this kind of occupation." Man's brain has two hemispheres. These are practically two "personalities" residing in the same body. One Louis V, an excellent young man, had a great fright from a viper. Paralysis of the right side set in. He became violent, insubordinate, a coarse joker, an atheist. A curious test was applied by his physicians. By the aid of a bar of steel the paralysis was transferred to the left side. Immediately the right side seemed to regain life, and the "modest, gentle, respectful" Louis V. reappeared. "Automatic writing," says Mr. Myers, "is the action of the less used hemisphere."

But is this quite an adequate explanation? Mr. F. N. Schiller, the planchette writer, "cannot remember to have read or heard any old Norman French." But then it is suggested that his left hemisphere may have remembered some old French from a "magazine article." This is a little weak. It is suggested also that certain rhapsodies of "Lokendranâth" seem pieced together from similar eastern rhapsodies in the novel, *Mr. Isaacs*: but can unconscious memory piece rhapsodies together? Also how can it write in Hindustani in complete ignorance of that language? But Mr. Myers, like a puzzling tangler of string, destroys with one pull the complicated fabric of knots and convolutions that it had made our brain grow giddy to watch.

For he records that Mr. F. N. Schiller, for an experiment, put his hands on two planchettes simultaneously. It is announced also that this gentleman always thought

of other things whilst he was writing. The result was startling. A distinct message was on each planchette, one written from the last letter of the last word backwards, mirror fashion, the other written in the ordinary way. We thus certainly get three personalities—

1. An undergraduate, thinking perhaps and talking of the next boat-race.

2. A spirit, signing herself perhaps "Eudora," or "Johnson."

3. A third personality, piecing, perhaps, together "eastern rhapsodies," from *Mr. Isaacs*, and writing them backwards.

Plainly the theory of the right and left hemispheres of the brain breaks down; and if we still insist on pure physics, we must add the occiput or the chin for the third "soul," "mind," "personality."

But Mr. Myers is equal to the occasion. He starts a new theory—that of multiplex personality.

The Sœur Jeanne des Anges was the Superior of the Ursulines of Loudon, about 1660-1665. She was vexed by many "demons," "Asmodeus," "Behemoth," "Balaam," "Leviathan," "Gresil." Mr. Myers has seen a *fac simile* of a letter from "Asmodeus." Dr. Gilles de la Tourette has letters in his possession from the other demons. Each has his individuality, though all are malignant and foul. But we ask here, why should we go back to the year 1660, when we have evidence of controls or obsessing "demons" so much nearer home? Mr. Stanton Moses had his "Dr. Dee," "Bishop Wilberforce," "Imperator," "Rector." He held that these were actual entities. Mr. Myers holds that with the nun they were "objectifications of hysterical attacks. The difference is that Mr. Myers does not attempt to use the verifying process to his theory. Mr. Stanton Moses does. He writes thus—

"No theory of 'unconscious muscular action' or 'subliminal consciousness' will cover the facts, and a theory that will not cover the facts, is self-exposed. Therefore we must search for something better. Is it so strange that that, which has been a matter of common and uni-

versal belief in all ages of the world should continue to be believed? Is materialism, then, sapping the faith which has been universal among men, and substituting for it that pale abortion which is known by the name of Agnosticism? There has been invented, chiefly by the devices of the Society for Psychical Research, a method of approaching the investigation of these subjects which any real student of psychical science knows to be fatal to success. In the last *Proceedings of the Society for Psychical Research*, Mr. Richard Hodgson has an article of insufferable length dealing with the mediumship of a lady in whom he has come to believe, though he starts in this frame of mind in his investigations: 'I need hardly say that in estimating the value of my own and all other sittings, I was compelled to assume, in the first instance, that Mrs. Piper was fraudulent, and obtained her information previously, by ordinary means, such as inquiries by confederates, etc.' A man who starts on the investigation of psychical matters in that spirit will be apt to find what he brings with him. It is interesting, however, to find that, as the result of his inquiries, Mr. Hodgson states enough evidence to show that fraud on the part of Mrs. Piper is very far from being an adequate explanation of what he himself observed.

What does my friend Mr. Elliott Coues say to the case which I publish in my little book, *Spirit Identity*? In the month of August, in the year 1874, I was staying with Dr. Stanhope Speer, at Shanklin, in the Isle of Wight. We had usually a sitting each evening, and at one there came a spirit who said that he had passed away from this world on August 5th, at the age of eighty-three years one month and seventeen days. He gave the address of Brooklyn, U.S.A. I do not dwell on the method by which this information was communicated, though it was very remarkable. The deportment—I suppose I may use the word with regard to a table, since Professor Tyndall has used it in regard to the weather—was very remarkable. Hands not touching it, the table rose in the air, quivering with excitement as we called the alphabet, until the required letter came. Then the table came down with a crash which would have seriously

hurt the foot of anybody who had been under one of its legs. The message given was that he had been a soldier in the war of 1812, and had passed away; dates and facts absolutely true. He gave, for instance, the date of his departure as August 5th. Now, these are precise facts. Neither I nor my two friends had ever heard of such a person as Abraham Florentine. I put into the *Spiritualist* a request that inquiries should be made in America, and the result communicated to me. To make my story short, I may state that the 'Claim Agent, Wilson Millar,' who writes from Washington, on December 13th, 1874, certifies that, 'being in the possession of all the claims for service in that war, in those records appears the name of Abraham Florentine, of Brooklyn, New York.' I may add also this:—

'GENERAL HEADQUARTERS, STATE OF NEW YORK.

'Adjutant-General's Office, Albany,

'January 25th, 1875.

'SIRS,—In reply to your communication, dated January 22nd, I have to furnish you the following information from the records of this office:—Abraham Florentine, private in Captain Nicole's Company, 1st Regiment New York Militia (Colonel Dodge), volunteered at New York on or about the 2nd of September, 1814, served three months, and was honourably discharged. He received Land Warrant No. 63,365 for forty acres. The above is taken from the soldier's sworn statement, and not from official records.

'Very respectfully,

'FRANKLIN TOWNSEND, Adj.-Gen.

'Colby and Rich,

'No. 9, Montgomery Place, Boston.' "

Here is an account of another spirit. It came to a séance thus recorded, by Mrs. Stanhope Speer:—

"January 25th. We met as usual. Scent and spirit-lights came at once, and a spirit rapped for alphabet, and gave the name of 'Thomas Wilson, Bishop of Sodor and Man,' and many minute details, all unknown to the circle. He said, in answer to questions, that he was born at Burtol, in Cheshire, December 20th, 1663; died March

Christian Kabbalists. Through Paracelsus, Reuchlin, Boehme, Eliphas Lévi, and also Madame Blavatsky, this Kabbalism has been filtered. The Kabbalah taught amelioration by rebirths on earth. The Kabbalah taught that the real life of man only begins when he has purified his soul sufficiently to effect an union with En Soph, the Soul of the Universe. Disgusted with the levity of spirits at séances, and with the paltry scheme of life that many of the "Spiritualists" still retained, the Christian Kabbalists seized these two dogmas with avidity. With the first they have helped much to ennoble the movement. But by substituting the Jesus of popular theology for the transcendental En Soph of the Kabbalah, they certainly do not represent accurately the high mysticism of Simon ben Jochai. They hold that the voice in the breast of man is not a dead mortal, but Jesus in person. This was the Demon of Socrates.

Now each of these theories may, perhaps, be the one right one, but the position of Mr. Stainton Moses always was that there is not a tittle of evidence to support any one of them. On the other hand, he had quite a mass of evidence in favour of his contention. Science has one mode of procedure, namely, to apply the verifying process to theory. The "spirit" was called upon to prove his identity by narrating facts unknown to the medium and his friends. I have given many instances of this. One very striking one recurs to me.

At Shanklin a spirit came to Mr. Stainton Moses and gave the name of a lady that I once knew. This was Mrs. Cowper Coles, the widow of the inventor of the turret ship. By the writing, termed automatic, she gave her name and the date of her birth and death. Mr. Stainton Moses has often told me the story. He asked, "Why do you come to me?" "Because you passed," she said, "near my grave to-day, and that has put me in harmony with you." "I passed no graves to-day." "You did. Take the same walk to-morrow, and I will try and influence you."

Mr. Stainton Moses went out next day, and near a lane was induced to look over a wall. There, in a cemetery, was Mrs. Cowper Coles's tombstone, recording the date of

her death, but not her birth. Mr. Stainton Moses made inquiries; both were accurate.

We now come to, perhaps, the most remarkable psychic experience of the century. It was led up to by a curious chain of events all long thought out from first to last. A spirit named "G" came to the sances of Mrs. Stanhope Speer, and emphasized his presence by producing, without the aid of any instrument, sounds that imitated a harp played with skill. Again and again he came. He announced that he was William Grocynt the teacher of Erasmus, who calls him "Patronus et Preceptor." He died at Maidstone, in 1599.

"G. manifested, making more beautiful sounds than usual; he answered our questions on his musical instrument, which sounded like a harp. He said he knew Erasmus, that he was seventeen years of age when he came under his instructions; he also knew Melancthon and Luther, of whom he did not express much approval. Mentor then showed us lights, not equal to those we had previously had, but he was able to brush our hands with the drapery surrounding them, which felt very fine and soft, like Indian muslin. Then G. gave five twangs on his harp for the alphabet, spelling out the word 'Break.'

"G. manifested freely, and much cool scented air was blown over us. The peculiar ticking sound then came between the medium and myself. Many spirits seemed trying to manifest. At last we managed to open communications with one, who told us, through raps, that many spirits from 'long beyond' were present, that she was the spirit of my old friend, C.F., who had passed over seventeen years ago. She had come from Bonchurch, where Mr. S. M. had been that afternoon with Dr. S., and had stood by her grave, and talked of her. This had attracted her to them. She said she was happy, and had joined her mother and sisters. I inquired if she had met my father. Answered, 'No.' 'How did you hear of his translation?' 'Through Miss Kirkland.' 'Do you often see her?' Many raps followed this question, giving the idea of pleasure. Other questions were asked and answered, and the alphabet called for. Message

rapped out: 'I must depart. Adieu.' This word the spirit in earth-life always used at the end of her letters. I looked over a bundle of old ones, and found it at the end of each. Catharine then, through the alphabet, rapped out 'Break.' We found under the table a piece of marked paper, with the letters 'C. F. passed seventeen years'; signed 'Rector.' Upon returning to the room—we heard the same sound that was made the previous evening by the spirit calling himself H—1. He solemnly assured us it was himself. Dr. S. said: 'Will you give us a sign of your presence?' 'We will; wait; join hands.' After waiting for a few moments, light was asked for, and we found on the paper we had placed under the table the name of H—1 and X Rector.

"January 2nd. Soon after meeting this evening a spirit came, giving the name of 'Henry Sprateley.' He told us through the alphabet that he had lived at 'Moor Cottage, Maidenhead'; had died there December 24th, 1873, and Imperator had selected him to come and give us proof of identity. The spirit then left, and Mentor came and tilted the table. After that an old friend of Mr. S. M.'s came and gave his name and birthplace, and answered many questions, since verified. G. then bid us 'good-night' on his musical spirit-instrument. After we had lighted up we found paper under the table with the initials of Mr. S. M.'s old friend, 'F.S.A. Rector.' We wrote the next day to the post-office, also to the Vicar of Maidenhead, making inquiries for the late Henry Sprateley, but received no answer. We heard later on that the Vicar was absent from Maidenhead. A month after the séance had occurred, I suddenly thought I would write to the present occupier of 'Moor Cottage,' asking if a Mr. Henry Sprateley had resided there. By return of post I received an answer from the son, saying he was the present occupier of the house, but that his father, 'Henry Sprateley,' had lived there until his death, which happened last December 24th, 1873. This was an excellent test, as no one in the circle had ever heard the name of the spirit or cottage, or circumstances of death, until they were given in the circle by the spirit, and



verified afterwards by the son, a perfect stranger to all of us.

“September 16th. This evening the circle met under the usual conditions. G. manifested quickly, making most beautiful musical sounds, and through them answering our questions. Mentor wafted perfumed air over each of us. There were many different raps and sounds made on the table, one foreign to the circle. It was like a grinding disintegrating sound on the table. We asked who it was, and whether the spirit could communicate. The message was given, and then Mentor rapped, and also Dr. Dee, who told the medium he had impressed him when in Dublin to look at his magic mirror in the Dublin Exhibition. The medium had visited it the previous summer. The spirit-lights this evening were fainter, but moved about with great rapidity. They formed behind the medium, played round him, and then darted over the table, and nearly up to the ceiling. One light lasted for a very long time, and rapped twice upon the table behind the medium. G. again manifested, making sorrowful, weird-like sounds. Not liking these, we closed the séance. These sounds were accounted for afterwards, as the medium's mother was in great sorrow, and her state reacting on him caused the melancholy wailing music.”

But another experience was still more strange. One still night at Eastbourne, when the pier was deserted, Dr. Stanhope Speer and Mr. Stanton Moses suddenly heard Grocyn's harp playing vigorously. For an experiment the Doctor went away several paces from the spot where Mr. Stanton Moses was standing, and still along the pier railing came the sound of the harp.

We come now to the strange sequel. The Rector of Shepperton happened to have a son at the University School. Learning from his boy that a master there was Mr. Stanton Moses, he recognised an old school-fellow to whom he had been much attached. He invited him to the Rectory. Mr. Stanton Moses came for a day or two, and in his bedroom at night was much disturbed by Grocyn suddenly twanging his imaginary harp with loud

sound. This irritated him, and surprised him also. It had been long silent.

The next day the Rector had to go to a Communion Service, which Mr. Stainton Moses evaded. He was left in the library, and amused himself by looking over some old magazines. Suddenly he came across the annals of the Shepperton Rectory. To his astonishment he found that Grocyn had once been rector there. When his friend came in he cross-examined him.

“Yes, you slept in Grocyn’s room last night. Erasmus was in this room.”

## CHAPTER XI.

### *THE SPIRIT "IMPERATOR."*

I NOW come to the dialogues between a clergyman and a spirit. These were written automatically; that is, Mr. Stanton Moses's hand and pen were used by the spirit to write the answers to his questions and his objections. These he usually wrote at the top of a blank page, and the answers were written underneath. A religious controversy runs through much of these dialogues. It is his Future fighting with the Past, the Higher Christianity opposing the Lower. The Gnostics of the earliest Church, that of Jerusalem, drew a distinction between "Jesus" and "Christ." Jesus was a man, fallible until the dove descended on him. The "Christ" is the Divine child, born of the Virgin Sophia, and Spirit the "Father." This is the Christianity of Anna Kingsford and a long line of teachers. On the plane of matter the Christian legend is irrational, and the atonement is disproved by modern geology, which shows that death and strife, far from having come into existence six thousand years ago, are to be traced in earth's earliest records. But the Christian legend on the plane of spirit is sound sense. The Resurrection of the Christ is the change from corpse-like animalism. And Spiritualism has shown that "Heaven," "Hell," and "Judgment" have also common-sense interpretations. It has taught that there is but one great law in the occult as well as the seen world. This is the great law of attraction, which draws up at death the pure to their fellows, and holds down the grosser spirits to the earth plane. The first can come down and help the second, but they are drawn back again. The second cannot mount until they are

purified. This great law explains the mysteries of friendship, love, aversion. It is rational and harmonious, for it still makes the race help itself along, *en bloc* as it were.

Mr. Stainton Moses once said to me that occultism had seemed to him so rational, and its evidence so strong, that he had fully believed that in some fifteen years it would have conquered the world.

"This shows," he said, "the danger of prophecy. Nothing has turned out as I thought. But the unexpected has occurred. Its subtle essence is everywhere, in the pulpits, even in the lecture rooms of science. Preachers talk of hell being a state of the soul, and question devout ladies about their inner progress."

It has been objected that these dialogues might have been written by a Unitarian young lady of seventeen. The London President of the Theosophical Society has gone further. He says that they touch only the "outside husk" of occultism. It is quite a pity, he thinks, that a man of the mental vigour of Mr. Stainton Moses should have listened to such "vampires."

A few words may not be out of place. "Imperator" himself has a noteworthy remark. He says that the "teachings" and the séances should be considered together. With great care and patience a medium was then developed, and a mass of evidence quite unexampled in occultism was furnished from the dead,—names, dates, and places, all capable of verification. And all these dead men have borne testimony to the fact that they know nothing about the efficacy of the "atoning blood," and other postulates of outside Christianity.

We must go a step further. Again, we must try and throw ourselves into the minds of the communicating intelligences. Plainly, "Imperator" knew much more of modern controversies than he reveals. But he wanted not to push the young clergyman into —, but to push him back from the abyss. It was perceived that Mr. Stainton Moses had, in a marked manner, the mysterious gift that we call mediumship. He had strong religious convictions. He had a methodical, fact-loving intellect. He represented many thousands of his contemporaries. He represented the nineteenth century. Imperator

sought not to root out his religion, but to spiritualise it. He says this distinctly.

"And now, friend, you will see the bearing of this on your difficulty. We have endeavoured not to uproot from your mind the views which you have entertained of theology, but to modify them.

"So much truth is given as man can grasp."

The theology was led up to by some remarks of "Imperator" upon "the spirit creed of God." This, "in place of an angry, jealous tyrant, reveals a loving father." It fails to "recognise any need of propitiation." Also, it is quite unable to conceive Supernal Wisdom, "vindicatively punishing a transgressor and requiring a vicarious sacrifice." The God of popular theology is an eastern Rajah enthroned in heaven, and receiving the flatteries that eastern monarchs delight in. "No such anthropomorphism finds place in our creed. We know infinitely more about this benign Being than you do, but no one has ever seen him."

"I objected to this statement," says Mr. Stainton Moses, "which did not by any means commend itself to me in my then state of opinion, that it was incompatible with the received teaching of the orthodox churches, and that, as a matter of fact, it traversed some cardinal doctrines of the Christian faith. I suggested that the message might have been adulterated by passage, and that much was omitted that I regarded as essential. If it were pretended that such a code was complete as a rule of life, I was prepared to argue against it."

*Imperator.*—"That which has been told you in its outline is so far correct; but it does not pretend to be a perfect delineation of truth. It is but a faint outline, blurred and blotted in many ways, but substantially truthful. Doubtless it contravenes much which you have been taught to believe as necessary to salvation. No doubt it seems to the unprepared spirit to be new, and destructive of the older forms of faith. But it is not so. In its broad outlines the spirit-creed would be accepted by all who have thought at all on theological subjects without trammel of preconceived ideas, and without fear

of the consequences of seeking into the truth. It would be commendable to all who are not hampered by old prejudices. We said that we must clear away much rubbish; that the work of destruction must precede the work of construction; that the old and unserviceable must first of all give place; that, in short, we must clear before we can build."

*Mr. Stainton Moses.*—"Yes, but the rubbish you seem to me to be clearing away is precisely what Christians have agreed in all ages to consider cardinal doctrines of the faith."

*Imperator.*—"No, friend; not quite so. You exaggerate there. If you will read the records which so imperfectly record the earth life of Jesus, you will not find that He claimed for Himself any such position as the Christian Church has since forced upon Him. He was more such as we preach Him than such as the Church, called by His name, has made Him."

*Mr. Stainton Moses.*—"I cannot think so. And the Atonement. What do you make of that?"

*Imperator.*—"It is in some sense true. We do not deny it. We do but fight against that crude human view which renders God contemptible, and makes Him a cruel tyrant who needed to be propitiated by His Son's death. We do not detract from Jesus' work when we disavow the false and dishonouring fables which have gathered round His name, and have obscured the simple grandeur of His life, the moral purpose of His sacrifice. We shall have something to say to you hereafter on the growth of dogma until an assumption becomes established as *de fide*, and its rejection or denial passes for mortal sin. Were God to leave man to his own ends, it would be held to be a mortal heresy, deserving of eternal burnings, to deny that the Supreme has relegated to a man one of His own inalienable prerogatives. One great section of the Christian Church would claim infallible knowledge for its head, and persecute in life and condemn in death, even to everlasting shame and torment, those who receive it not. This is a dogma of late growth in your very midst; but so all dogmas have grown up. So it has become difficult, nay, impossible, for unaided human

reason to distinguish God's truth from man's glosses upon it. So all who have had the boldness to clear away the rubbish have been held accursed. It has been the story of all time. And we are not justly chargeable with wrongdoing if from our superior standpoint of knowledge we point out to you human figments of error and endeavour to sweep them away."

*Mr. Stainton Moses.*—"Yes, that may be. But the belief in the divinity of Christ and in His atonement can scarcely be called dogmas, which are of human growth. You always prefix to your name the sign of the cross [✠ IMPERATOR]. Were you a Christian while you lived on earth, or were you not? If not, why the Cross? The whole question ultimately concerns your identity. I cannot see how your teaching coincides with your belief when you lived on earth. It is pure and beautiful, but surely it is not Christian."

*Imperator.*—"Friend, the sign, which is emblematic of the life and work of Jesus Christ, is one that cannot fairly be prefixed to much that now passes current for His teaching. Those who are known to you as the orthodox defenders of the Christian creed tell you that a mysterious person—one of the three individual persons who compose the Undivided Trinity—took possession of the minds of certain men, and through their organisms gave to the world a body of truth, which was whole, complete, and of eternal force: a system of Divine philosophy from which nothing might be removed under the direst ban, to which nothing would ever be added; and which was the immediate word, the very utterance, the mind and will of God, containing within the whole body of truth, actual and potential, contained in divinely worded phrases and expressions. In short, the Bible is the Word of God, both in matter and form. Hence you will see that doctrines the most tremendous, and conclusions the most far-reaching, may be founded on mere words and expressions.

"We say that the sacred books which make up your Bible, together with many others that are not included in it, are the records of that gradual growth in knowledge of Himself which the great and good God has given

to man. The principle which pervades these utterances is one and the same; identical with that that governs our intercourse with you. So much truth is given as man can grasp.' The inspiration is Divine, but the medium is human."

*Mr. Stinton Moses.*—"Such a creed would not be acknowledged as Christian by any member of a Christian Church. It is contradictory to the plain words of the Bible. Such views appear even to be the subject of special denunciation, as those of Anti-Christ. Vaguely beautiful, they have a tendency to take the backbone out of faith."

*Imperator.*—"You have been taught in the creeds of the orthodox Churches to believe in a God who was propitiated by the sacrifice of His Son, so far as to allow a favoured few of His children to be admitted to an imagined heaven, where for ever and for ever more, with monotonous persistence, their occupation should be the singing His praise. The rest of the race, unable to gain admission to this heaven, were consigned to a hell of indescribable torment, perpetual, endless, and intolerable.

"A life of gross sensuality, or of sloth, or of offence against all law, is remediable by an act of faith. The grossest and most sensual ruffian may, by a cry on his death-bed, find himself instantaneously fitted for admission into the immediate presence of the God whom he has all his life blasphemed. He, the impure, base, degraded, earthy spirit admitted to the association of the refined, the noble, the pure, the holy, in the immediate presence of the stainless perfection of the all-pure God.

"Of this 'God of Love,' who shows His love in such a fashion, we know nothing. He is of man's fashioning, unknown to us. We do but ask you to wonder with us at the presumptuous ignorance and folly which has dared to paint such a caricature of the pure and holy God. The God whom we know, and whom we declare to you, is in very truth a God of love. Between Him and you are ranks of ministering spirits, the bearers of His loving message.

"And you, yourselves, what of you? Are ye immortal souls who, by a cry, a word, by an act of faith in an



unintelligible and monstrous creed, can purchase a heaven of inactivity and avoid a hell of material torment? Verily, nay! Ye are spirits placed for a while in a garb of flesh to get training for an advanced spirit-life, when the seeds sown in the past bear their fruit, and the spirit reaps the crop which it has prepared. Immutable laws govern the results of deeds. Deeds of good advance the spirit, whilst deeds of evil degrade and retard it. Happiness is found in progress, and in gradual assimilation to the God-like, the perfect. The spirit of divine love animates the acts, and in mutual blessing the spirits find their happiness. For them there is no craving for sluggish idleness."

*Mr. Stainton Moses.*—"I have thought very much of what has been said by you, and I have read some of it to a friend in whose judgment I rely. It is startling to find doctrines of Christianity, which we have been taught to consider as essential dogmas of the faith, denied under the symbol of the Cross. Will you state clearly for me what position you assign to Jesus Christ?"

*Imperator.*—"You inquire from us what position we assign to Jesus, the Christ. We are not careful to enter into curious comparisons between different teachers who, in different ages, have been sent from God. No spirit more pure, more God-like, more noble, ever descended to find a home on your earth. The self-denying love which would benefit humanity even at the sacrifice of life, and home, and earthly happiness, the pure spirit of the Christ, this is what we would declare to you as the God-like spirit. This self-abnegation and incarnate love is that which can atone for sin and make man like to God. This is the true Atonement."

In this manner, at great length, this curious dialogue proceeded. I have condensed the argument. It was long before the clergyman yielded. He called the change at last a "regeneration."

"The particular communications that I received from 'Imperator' mark a distinct epoch in my life. It was a period of education in which I underwent a spiritual development that was in its outcome a very regeneration" (*Spirit Teachings*, p. 7).

I have only room for a little more.

*Mr. Stainton Moses* —“Do you know more of God than you did on earth?”

*Imperator.*—“We know more of the operations of His love. He is known to us by His acts. We know of Him, but we know Him not.”

*Mr. Stainton Moses.*—“Is there a devil?”

*Imperator.*—“Chiefs, many theſe are who govern, but not ſuch a devil as theologians have feigned.”

*Mr. Stainton Moses.*—“You have ſpoke of adyersaries. Who are they?”

*Imperator.*—“The ſpirit which has found all its pleaſure in bodily gratifications, when the body is dead, ſtill hovers round the ſcenes of its former memories. It lives over again the bodily life in the vices of thoſe whom it lures to ſin. Round the gin ſhops of your cities, dens of vice haunted by miſerable, beſotted wretches, hover the ſpirits who in the fleſh were lovers of drunkenneſs and debauchery. Could you but ſee how in ſpots where the vicious congregate, the dark ſpirits throng, you would know ſomething of the miſtery of evil.”

*Mr. Stainton Moses.*—“Who are the ſpirits who return to earth?”

*Imperator.*—“Principally thoſe who are neareſt the earth. They conſerve moſt readily with you. Of the higher ſpirits, they who are able to return are they who have what is analogous to mediumiſtic power on earth.”

*Mr. Stainton Moses.*—“Will you write for me the laſt line of the firſt book of the *Aeneid*?”

*Imperator.*—“*Omnibus errantem terris et fluctibus aestas.*”

*Mr. Stainton Moses.*—“That is right. But I might have known it. Can you go to the book-caſe, take the laſt book but one on the ſecond ſhelf, and read me the laſt paragraph on the ninety-fourth page?”

*Imperator.*—“I will curtly prove, by a ſhort hiſtorical narrative, that popery is, etc., etc.”

The entire ſentence was accurately given. It was from a book, entitled, Rogo's *Antipopopriestian*. *Mr. Stainton Moses* had quite forgotten the book.

## CHAPTER XII.

### *DEATH OF STANTON MOSES.*

THESE dialogues seem to me of the highest importance.

What was the main object of "Imperator"? This must be kept steadily in view.

As I take it, it was this. He wanted, to a sceptical century, to give evidence of a world of ghosts, evidence really scientific, evidence that added the verifying process to the simple surmise of the other schools of occultism.

He wanted a witness strikingly trustworthy, a medium through whom not one spirit from the dead, but dozens of spirits could prove their prolonged existence, by stating facts concerning their past lives that were unknown to the medium and his friends, but were verifiable afterwards.

Bearing this in mind, it is plain that the dialogues must be considered simply as means to an end. They may be judged prolix. They may be charged with going too much over the same ground. But their object was to turn a conscientious and somewhat stubborn clergyman into a very remarkable medium.

What makes a medium?

This is a difficult question. American statistics fix the present number of Spiritualists in Europe at eleven millions. And yet from these vast cohorts only four or five mediums of the power of Mr. Stanton Moses have yet emerged. And these have been professional, not excepting Home. It has been their interest to produce remarkable phenomena. This, justly or unjustly, has told against their trustworthiness with sceptical inquirers. The interests of Mr. Stanton Moses were quite the other way. He had to give up his scheme of life, his profession, his creed, his means of livelihood. Also he had to give up

many friends, for in a partisan body like the Church, lapses into Theism and other unpopular "isms" are seldom forgiven. Mr. Stanton Moses was able, zealous, sincere, eloquent. It is the opinion of those qualified to judge, that if he had remained in the Church his scholarship and talents would have placed within his reach the prizes of the profession. Mrs. Stanhope Speer, who knew him best, says that the great wrench was not effected in its entirety for many years. In these dialogues we see the struggle. As "Imperator" said, he was "violently positive." From early youth certain dogmas had been presented to him—a "common sense" religion, which he had got to believe was fully provable. To the last he never sympathised with mystics like Anna Kingsford, who maintained, with St. Paul and St. Clement of Alexandria, that the Bible had two meanings, the "milk for babes," and the deeper secrets for those who would escape from the state which is "spiritually called Sodom and Egypt." More than once he has inveighed against "mystical meanings" in my presence. A document should be matter of fact, he thought, and precise.

But with all his shortcomings he was plainly the man that they wanted, to push experimental occultism to its full development. And the greatest possible pains were taken to develop him. A very harmonious circle was chosen, the spiritualising influence of Mrs. Stanhope Speer being quite invaluable. Imperator was very angry when outsiders were admitted, for he well knew the dangers of physical mediumship. By degrees the dark séances passed on to light séances, to trance, to automatic writings, to visions, to direct writings. But these marvels, though useful, were only means to an end. A very astounding physical marvel takes place. One witness says it is due to a spirit. Another witness says it is due to the Higher Ego of the medium. A third witness says, it is simple conjuring. These are theories, and the verifying process cannot be applied. But when a spirit like Grocyn comes across the centuries with a mass of evidence that was practically buried, we come as near to the verifying process of science as the nature of the case allows. Mr. Stanton Moses (*Spirit Teachings*, p. 183) de-

clares that all the tests furnished, and their name was legion, were always accurate.

My task is nearly over. Mr. Stinton Moses had a marvellous capacity for work, in spite of chronic ill-health. He toiled and toiled, working against the stream, straining to pull along his unpopular cause.

I will give a few extracts from his letters and other writings.

“BEDFORD, August, 1877.

“I have spent three hours this morning writing an account for the *Spiritualist* of what I have seen and done spiritually. You will read it, so I need not repeat myself. But it is right that I should tell you of the third visitant, who is Mrs. B. To make myself intelligible I must go back. For some time after coming here I was very ill; the mere act of reading a newspaper produced violent headache and prostration, and I was good for nothing. As I recuperated there supervened a most beautiful state of clairvoyance. I lived as much in a world of spirit as of matter. When I began to recuperate I went for a few days—Wednesday to Saturday—to town, to get books, papers, and change of scene—that as much as anything.

“When I went my mother had an old friend who was ill—nothing more—just ill. When I came back, as I entered the room, she stood by my mother’s side as plain as could be. I did not know her in the flesh, but, instinctively, I knew who she was. ‘So Miss G. is dead,’ I said. ‘Yes, and buried.’ (The words sounded in my ear.) ‘How did you know? I suppose you heard as you came up through the town.’ I did not disturb the idea. I noted the dress, etc., and got it all out of my mother, except a very curious brooch she had on. My mother knew nothing of that. But next day she went to see the lady who was acting for Miss G., and came back with the identical brooch in her hand. It had been left her as a memento.

“All the time there was a form, or rather a presence, which interested me, but of which I could make nothing. It was, like many another I have seen, a *presence* trying

to make itself felt. It seemingly failed, until my mother, who was looking at the *Standard* (I had previously been told by Mentor that my attention would be directed to the identity of the spirit), read out the notice of Mrs. B.'s death. At once came the voice in my ear, and I knew that the presence was Mrs. B.'s. After, when I went to bed, came musk from Mentor, and then a long written communication (signed by Rector, Mentor, and Maguš), the gist of which only I can give. It said that she is gone from this sphere, that she is reunited to her husband, and that her great delight will be in raising him from the state in which he has so long been imprisoned—. She experienced *no* pain, but was released with *no interreal* of unconsciousness, being of ripe age. The struggles you describe I asked about, and was told that no pain was connected with them. When they took place the spirit was already in process of being released. They say that the union between her husband and herself was real and permanent, and that he could not progress till her spirit was joined to his. Now they both go on together, and have already left the sphere of our earth. She was never unconscious, even for a moment. I don't think I have left out any very material point. She is gone, and her husband with her. Wonderful reunion! I think I have told you the gist. There is more that you must read, but not anything of moment. What I have written for the *Spiritualist* is very guarded, but you will read between the lines. I have had a wonderful access of evidence during the past week, and am disposed to make much of it. I entertain no doubt as to the reality of all the presences, and believe that similar surroundings would make them more frequent."

"BEDFORD, September 23rd, 1881.

"The President (Garfield) is gone at last. Poor man, how he suffered. I had a very curious spiritual experience in connection with his death. I had gone to bed on the evening of the 19th full of expectation that he was near the end, and with my mind a good deal occupied by the thought. On awaking on the morning of the 20th, I was aware of some spirits who were trying to com-

communicate—Epes Sargent, B. Franklin, and others. This was by my watch 5.50 a.m. They said in effect, 'The President is gone. We were with him to the last, and all our efforts to keep him were unavailing. We tried hard, for his life was of incalculable value to his country,' and more to the same effect. I asked why they came to me. They said that my mind was full of the subject, and that they were interested about me. They gave me the impression of grave danger impending over America in consequence of this death. They also talked about his treatment, and then left. Now there was nothing in all this inconsistent, in the mind of a man who knows nothing of spirit, with natural order. I went to bed full of expectation that I should hear of his death. Between sleeping and waking I dreamed that he was gone. The reflections made were such as would occur to me. That would be the scientific explanation. As a matter of fact the whole thing took place as I tell you, and I have no doubt at all that these spirits, seeing further than we, and used to talk to me, did what they say they did, and told me of it. We take the *Daily News* here. When I came down to breakfast, I turned to it, and found, to my surprise, a not unfavourable bulletin. (We now know that the doctors were not alarmed half-an-hour before death.) I was convinced, however, that he was dead, and went off to the station to get a second edition, which I knew would be published. There was none, and no rumour of any kind. I came home, and went again at 12.30; found that a vague rumour was circulating. A passenger from London had said that he had heard that the President was dead. That was all. I went again as soon as I thought the evening papers would be in, and at 4.30 p.m. got a *Globe* with the intelligence."

"There never was, so far as we know, a time of more vigorous attempt on the part of the world of spirit to influence this world of ours. It is a hard time for those who are sensitive to these influences. They feel them first, and they cling to them last. For no time of such a sort can possibly come without revolution. No doubt it may be that the upsetting may be a matter of one's own

physical state, or shall we say of one's psychological state? For the externalisation is only the resultant of the inner self. We are what we make ourselves, and that which meets the eye in our daily life is only the expression of that which is our real self—the soul that will live when the body is done with.

“If this new revelation comes home to us, it is a continuation of that which has already come to us—a continuation of that Divine work of which the Bible is the record. No doubt the Scriptures contain some things which are not now acceptable to our knowledge, or what we please to call by that name. But they are an imperishable record of the evolution of man's soul. That is what we have to study, and that concerns us most.

“We want the ‘Refiner's Fire.’ All of us as individuals: all of us as Spiritualists. The gold goes into the furnace and comes out, the dross remains behind. But the gold has been refined. The dross has gone, and only the fine gold remains. It seems to us that some such process is being spiritually carried on with us now—with us who can realise its need, which means only that we are fit to receive it. If we may borrow the phrase, it is a purgatorial time: a time of searching and of trial. And Spiritualism is on trial too. It has revealed to us much that it is good for us to know. It has taught us much that we are the better for. But all the methods of Divine illumination are the same. ‘We have these treasures in earthen vessels.’ How could it be otherwise? We have to make the best we can of the opportunity offered to us. We must take the trouble to digest the food that is given to us.

“Some of it should be rejected at once on the ordinary common-sense of a plain-thinking man. It may be that the average man is unable to understand those new developments which do not at once commend themselves to his common-sense—which is the aggregation of his experience and knowledge: common-sense will prevail, and, we say, rightly.”

“Death is the great Revealer. For he shows to us the organised machine in the process of change. That which



we have known as a human being undergoes a change by his touch which reveals to us, if we think aright, a tenement from which the occupier has departed. There is in death, especially when its answer comes to the sigh of bereavement, something infinitely illuminative. It must be a poor soul, with nothing of the Divine faculty of imagination in it, that does not find in death an answer to many of its questionings. 'He is not here: He is risen.' There is the place where they laid Him: there is the body that they laid to rest: but 'He is not there.' We realise the truth with an instinct that all the refinements of a material philosophy have not wholly quenched. With his bones around him, with his instruments that can lay bare the whole mechanism of the body from which the spirit has fled, the astutest philosopher is driven back to the unanswered question, 'Where is she now?' The Spiritualist has no great difficulty in his reply, for he has never thought of the form as the man; but the Materialist, it always seems to me, must find the problem insoluble. And love finds the answer all too vague.

“My sister! thou hast found, the Master said,  
‘Searching for what none finds— that bitter balm  
I had to give thee— He thou loved’st slept  
Dead on thy bosom yesterday. . . .  
Lo! I would pour my blood if it could stay  
My tears, and win the secret of that ease  
Which makes sweet be e our anguish, and which drives  
O’er flowers and pastures to the sacrifice,  
As these dumb beasts are driven—men their lords;  
I seek that secret.’

“It is a secret that is revealed only to him whose eyes are open, whose spiritual senses are alert. And even he sees only through a glass darkly. For the mass of men, with their body-worship and all that is therein involved, real life begins only when death supervenes.”

This last quotation suggests some words of his that made a striking impression on me. Some three or four years before his death he was, for a moment, at death's door. He recovered, and came to a meeting at St. James's

Hall. A lady, a little lame at the time, asked me to help her to go to him. She congratulated him on his recovery.

He told us that for a long time he had been in a state of semi-torpor. He was aware that he had not yet passed the Great Boundary. But it seemed to him probable that he would never come back to earth life. The spirits of the dead were around him. Old friends were by him. "Imperator" and his other guides were palpable. He felt no fear; he felt no desire to return.

But his work was not yet accomplished, and he had to come back to life. Worse experiences were in store for him. His eyesight failed, but still he worked on at his newspaper, helped by a boy.

At Bedford, on 5th September, 1892, he died.

This is his last letter :—

*August 23rd, 1892.*

"MY DEAR COUES,—I am oppressed with the sense of Bundy's death. It is always with me. I am too ill to do much. Have put my paper in commission for September. Confidentially, I am very much afraid of myself. Symptoms are ugly. Gaps in memory. Traces of paralysis on the right side. But there is, I hope, no failure in mind.

"All things conspire now to worry me. Work does not kill. Worry does. I turn to you with strange longing.

"I am aweary—weary. I would that I were dead. I have a series of notices of Bundy, which I shall leave for my acting Editor. I am used up.

"Wearily, your friend,

"W. S. M."

APPENDIX, No. I.

GHOST WORSHIP.

WE have seen that the London President of the Theosophical Society condemns the teachings of "Imperator" on the ground that they are not "new."

Is this a blemish?

Modern science is giving us day by day larger ideas of God. The telescope, disclosing millions of suns, has made us believe that if we were to journey for ever and ever east or west or north or south we should still meet suns and systems. All this is forcing even the Churches to believe that God rules by large laws, and not by special interventions. Thus, if there is an unseen world as well as a seen world, and it is a fact that God wishes its existence to be known, it may be only dully, we must expect Him to proceed in this as He proceeds in the rest of His economy. He gives man rational faculties, He gives man facts, and He allows him to deduce the inferences for himself.

Has man had hints of an unseen world from very early times? Anthropology says, Yes. It points to the barrow, the dolmen. The barrow is a heap of earth, or stones, with a little stone chamber in the middle. It was the first rude house of the living man. And then it became the rude home of the dead man.

The king of Ai was buried under a great heap of stones. Semiramis, the widow of Nimus, buried her husband within the precincts of the palace, and raised over him a great mound of earth. In the Trojan war Tydeus and Lycus are mentioned as having been buried under two earthen barrows. Hector's barrow was of stones and earth. Barrows are everywhere—in Asia, in Europe, in America. They belong to all ages, stretching back into

the very furthest past. In some we see evidence that the use of metals had been discovered when they were erected. In others, we find only the rude pottery and the rudest chipped flint implements of the earliest savage. And it has been pointed out that the Ganggraben, or passage graves, of Norway, correspond closely with the actual dwellings the Yurts of the Siberians, the "winter houses" of the Esquimaux and Greenlanders. Professor Nilsson, of Sweden, says that the Ganggraben are a "copy, development, or adaptation of the dwelling house; that the ancient inhabitants of Scandinavia, unable to imagine a future altogether different from the present, or a world quite unlike our own, showed their respect and affection for the dead by burying with them those things which in life they valued most—with ladies, their ornaments, with warriors, their weapons. They buried the house with its owner, and the grave was literally the dwelling of the dead. When a great man died, he was placed in his favourite seat, food and drink were arranged before him, his weapons were placed by his side, his house was closed, and the door covered up; sometimes, however, to be opened again when his wife or children joined him in the land of spirits" (Lubbock, *Prehistoric Times*, p. 90).

We see thus, that from the very earliest times man has had an idea of an unseen world differing little from the ghost world that Mr. Stanton Moses believed that he had cognisance of. This at once seems to imply the existence of the large law that we have hinted at. It is important that from the early ancestor worship, as it is called, all the gods, and rites, and mediators of the world's religions are said to have sprung.

What was this ghost worship? We have only to turn to modern China for a complete answer.

The Chinese have an official religion, with many festivals in honour of heaven and earth and the forces of nature. Confucianism proclaims annihilation at death. The Buddhists have their Karma, their heavens, their hells, their metempsychosis. But all this is put aside throughout the length and breadth of the Empire. There is but one sincere cult, the worship of ghosts.

An interesting paper on this subject is to be found in the *Chinese Repository* for 1849.—

“It is the usage of all ranks to have a place—a lararum—in the house, dedicated to the honour and the worship of its former members. Among the rich and honourable whose mansions are spacious, a room is set apart for this purpose, in which are the portraits or tablets of their ancestors from the head of the family down; or, in some cases, only the first progenitor, as representing all the succeeding generations. The titles of honour or office held by members of the family are also placed here, painted on large boards. Here the family collect on all public or private festivals; and whenever some extraordinary event, joyful or melancholy, has taken place in the family, they announce it to the ancestral groups, making them partakers in the joy and grief of whatever has happened.”

Here is a passage about the rites of this worship:—

“The ceremonies attending the worship of deceased relatives are few and easily performed. A servant, a child, or the keeper of the family temple, every morning and every evening, lights a few incense sticks, and bows before the tablets and shrines as he thrusts them into a tripod. On the new and full moons he buys a few candles and gilt papers, and burns them in the family sanctuary and at the threshold. And, lastly, in the spring and autumn he repairs to the grave and offers his prayers and petitions, accompanying his worship with fire crackers, burning papers, and offering a sacrifice of flesh, fruits, and spirits, which is then carried home to provide a sumptuous feast for the household. The occasion calls together the scattered members of the family, and the annual reunion being accompanied with good cheer and the pleasant company of loved ones, the worship of ancestors is indelibly associated in the minds of children with the most delightful recollections of youth. There is nothing revolting or obscene, no celebration of Bacchanalian orgies, no sacrifices of human beings.”

But the author of the article, who seems to have been a missionary, regrets that in “Chinese idolatry” there are

no "offerings of blood," no "sense of sin and the necessity of atonement."

When folks have a ghost-chamber in their house they must hold that ghosts can move about. An earlier idea seems to have been that the ghost lived in his tomb. Here is a requiem to be recited at a grave:—

"For ever rest in this fair city,  
Where pines and firs will comfort and cheer you!  
Friends and kin in crowds collect—  
Here at your dwelling to salute you,  
Our libations we pour.  
The beauty of a thousand hills is centred here,  
A winding stream spreads far and wide,  
The sighing firs will make you music,  
The dragon coils around to guard it."

But whether the ancestors be in the grave or out of it, the Chinaman holds that he has more power as a ghost than when he was alive. Here is a prayer:—

"The spring dews are now distilling their fertility, and my grief cannot be forgotten. Improve the time to examine and sweep the grave and visit the fir hall (the tomb). Prostrate I pray your protection to surround and assist your descendants that they may be powerful and honoured. Let every son and grandson in the house receive a happy sign, and become conspicuous over all, his fame rivalling the lustre of his ancestors. Looking up we pray you to descend and accept our sacrifice."

But other spirits besides ancestors are to be feared, the formidable Hau Tu.

"My ancestors quietly repose in this tumulus. At this genial period, when the spring is passing away, I worship and repair the tomb, and with solemn care lay out the sacrifice and libations to show the sincerity of my heart. Let your protection be over the sepulchres of my fathers."

The mystery of fire perplexed early races. In its presence a solid object was seen swiftly to melt away. Whither had it gone? They concluded that it had gone to the unseen world. There was a second fancy that an

image, a picture, a reflection in the glass, contained the soul. This is at the bottom of the Chinese idea that a toy house, toy doubloons, toy furniture, toy jewels, can be sent by fire to their ghosts. At one period of the year paper garments are offered up. And as some ghosts are poor, and have no rich friends to help them, a general feast for the pauper ghosts takes place once a year. There are grand illuminations, booths, flags, lanterns, prayers, priests, festivity. The priests "move their fingers in a peculiar way" to open the gates of hell. Out bounce the ghosts, and they take the spiritual portion of the feast. Then the beggars of the city scramble for the rest.

It has been well said that "ancestor worship belongs to no one race or creed. It is the link between the races and the common matrix of their creeds. It transcends all other branches in importance, and exceeds them in difficulty. It cannot be dealt with as history or as metaphysics, for both are born from it. In the mysteries of life and love its spring is hidden, and is not to be found unless sought for there. As on entering a sacred grove, here also we must deposit the profane vestment of opinion; nor would this (if practicable) be all. We must surrender for a time our judgment as well, and give up our wisdom as folly. For a clear eye will not give you to know man as if he were a crystal or a plant. The eye to see him by is the soul. Seek to know as a child seeks to know, and you will be able to judge as a man ought to judge. For this speculativeness must give place to reverence, knowledge to ignorance, science to superstition."

This ancestor worship of the Chinese is the basis of all our present difficulties in the country. Reverence for the father as the head of the family is their politics, their religion; and they say that Christianity offers a priest, a minister, a mediator in its room. Hence the animosity of the Conservatives, the soldiers, the secret societies. And judged by the narrowest rule of expediency, there is something to be said in favour of the Chinese system. At the family gatherings they rehearse the deeds of the most illustrious ancestors, they profit by their experience, they incite the emulation of the younger members. And we

now know how much heredity has to do with our morals, our health, our happiness.

India has had many creeds, but only one religion. This is the S'râdha, or worship of the ghosts. Creed-maker after creed-maker has gone counter to this. Later Vedism shut up the Pitri in its heavens and its hells. Brahminism proclaimed the metempsychosis. Buddhism had its Nirvâna. The Sunyavâdi proclaimed extinction, and the followers of Vishnu Moksha, three very similar ideas. Christians, Mussulmans, Agnostics have preached to the Hindoo. His ghosts have been changed into gods, into devils, into Buddhas, into mediators. But still he offers his boiled rice, his sugar, his honey, his fruits, his sweetmeats, his incense, to the ghosts as ghosts.

As early as the Rig Veda there were hymns to the Pitri. Here is one addressed to Yama, at first the Indian Adam, afterwards the Indian Pluto.

"Yama, place thyself on the altar of the sacrifice, with the ancestors. King, let the prayers of the saints summon thee. Accept our sacrifice. Come, Yama, with the honourable Angrases (the seven great saints) Seated on the grass I invoke Vasîswan.

"We have amidst our ancestors the Angrases, the Navagwas, the Atharwans, the Somyas, may we obtain their favour, their benign protection.

"Oh, dead man (the corpse), come to us. Come by the ancient roads that our fathers have traversed before thee.

"Behold these two kings, Yama and the divine Varuna, who rejoice in our oblations.

"Come with the Ancestors. Come with Yama to this altar which our piety has dressed. Thou hast cast off all impurity, come to this domain and den a body of brilliance.

"Oh, Ancestors, disperse. Go every one to his own side. A place has been set apart for the dead man. Yama permits him to come down and enjoy our libations, morning and night.

"Give our libation to Yama with Agni as a messenger. Offer to Yama a holocaust sweet as honey.

"Honour to the first one, the ancient Rishis who have shown us the way."



This is a hymn that might have been recited at a funeral four thousand years ago. I will make a few extracts from a paper published by the Calcutta Psycho-Religious Society, to show how strong the custom still is.

“We have said before that the Hindus respect the memory of their deceased ancestors like most civilised peoples; and they do more. They invoke the dead and offer food (cakes) to them! What are these cakes for? Do dead men eat? If not, where is the necessity? Or, is it a random shot, a shot in the dark, or is it a priestcraft? We will soon discuss all these questions as we go on. In the first place let us try to understand why the ceremony is called *Śrādhā*. The word ‘*Śrādhā*’ is derived from *Srodha*, or faith. The ceremony is therefore built on faith principally—on the faith that the spirits of the deceased do actually come to partake of the offerings made in gratefulness. It is a spiritual *Yaj.* Let us now see whether there is any sensible grounds for the belief.

“To show gratitude to the dead ancestors is a pleasing trait in humanity, which is acknowledged by all. To do the same, however, with flowers, fruits, rice, milk, sugar, etc., believing that the deceased do actually come to the spot and feel the pleasure of actual eating, is something which cannot be well understood, much less acknowledged by all. Herein therefore lies the difference. To assume the possibility of their presence, in the first instance, and then of their capacity for enjoyment of material things, presupposes—

“1st. Our intimate knowledge of the spirit-world and of the existence of spirit-life.

“2nd. Our power to invoke the dead and bring them back to earth for a while.

“3rd. The capacity of the spirits for enjoyment of material things—food for instance.

“Let us now see whether the ancients had any knowledge of spirit spheres. In order to test a truth or a class of truths, it is usual to have at first a clear statement of surrounding circumstances connected with them. If, for instance, an individual or a nation believes that one man can affect another by the odours of his body, or by subjecting one to inhale the smell of the wearing apparel of

another for a length of time, it would be necessary on the part of the individual who wants to test the truth or otherwise of the belief, to have a clear statement of all the circumstances connected with it. To ignore a fact or a truth merely on the ground that it is not known to all men is repugnant to all experience and reason. The truth of the circulation of the blood in the animal body flashed originally in one mind only, and though not accepted at first by all remained nevertheless a truth. To say, therefore, that the Śrādhā ceremony cannot be true on the ground that it is confined only to *one nation* on the face of the earth, will be saying something contrary to previous experience.

“Before we venture to discuss on each of the subjects mentioned above, we may note, by the way, that the ceremony is not only to be observed once a year, but a person may do it every day if he wishes to do so. It is, however, incumbent on him to do it at the time of a marriage or an ‘upanayana’ (the ceremony of the investiture of the holy thread), etc.; and hence Śrādhā is divided into five kinds:—

“1. Nityā (daily).

“2. Nymitikā (annual).

“3. Kānyā (when a kāśānā or object is to be attained).

“4. Brīdhī (when blessings of the departed ancestors are to be asked before marriage, etc.).

“5. Pārbānā (on a new moon day, ‘Urīhodoyā yoyā,’ etc.).

“Little cushions of Kusa grass are spread for the ancestors. Lamps are lit. The offerings are spread out.

“The ghosts are divided into three great classes:—

“(a) Those that are said to be *Sthirāmurti*, i.e., possessing forms.

“(b) Those that have no form, but can assume form at will. These are called *Itcha-murti*.

“(c) Those that are without form and wish not to assume form are called *Amurti*.

“These are subdivided into seven classes:—

1. Shubhāśubhāra.

2. Bahurshad.

3. Agnis’iwata.

4. Krabad.
5. Upahata.
6. Arjapa.
7. Sakahsi.

“Among these the first three are *Amurti*, the fourth and fifth *Itchamurti*, and the sixth and seventh *Sthiramurti*.

“The substances used in the invocation are—

“Besides boiled rice and vegetables, sugar, honey, fruits, and sweets, (1) kusa, (2) til, (3) light, and (4) incense.

“And as to the ceremony, the writer says:—

“The souls of the ancestors of a man are supposed to belong to either of the two classes of spirits called *Sthiramurti* or *Itchamurti*; for they are said to be not beyond the region of physical ether. *Scādhdā* is therefore necessary for them. Their memories are yet green and they retain the affections of the earth, and watch with interest their descendants. *Scādhdā* is performed for the Priti or satisfaction of the deceased ancestors, commencing from father or mother up to great-grandfather or great-grandmother. The souls of the ancestors further remote are supposed to have passed beyond the limits of the physical to luminous ether, and consequently they retain not the affections of the earth. This is the general ruling in respect to the performance of *Scādhdā* ceremony. It is not meant to make provision for individual cases; and hence it is necessary on the part of the performer of the ceremony to have some spiritual education, to know whether his father or grandfather is earthy or ethereal spirit, to be able to discharge his duties to his own satisfaction and to the satisfaction of his ancestors. To pass the night previous to the performance of *Scādhdā* in gay company, and to swamp oneself in gin and brandy, and then to sit the next day to discharge the onerous duties of *Scādhdā*, is a grave insult to the memory of one's own ancestors and an unpardonable sin in the eyes of God. We would advise our young men rather not to perform the ceremony at all if they cannot reverentially fulfil all the essential conditions of the ceremony, than to do it in a way which is repugnant to reason and conscience alike.”

After cremation the calcined remains of the Hindoo are

placed under a chettri (umbrella-shaped building), the daughter of the Dolmen. A friend of mine, Major Keith, tells me that he has seen the statues of the Scindiahs under these chettris treated like living beings, and supplied with daily dinner, a hookah, etc.

All this is precisely similar to the Egyptian worship of the Manes taken over by the Greeks and Romans. Bishop Warburton wrote an elaborate work to show that the great secret of the ancient mysteries, the "whole delusion," was, that all the gods, Jupiter, Osiris, Bacchus, Mars, were in reality dead heroes.

Early Buddhism took over the dolmen and made it into the tope. Under these pompous mounds Buddha's ashes, and those of Ananda, Sariputra, and the other great Buddhist saints, were kept and worshipped. The earliest ritual was entitled, "The Praise of the Seven Great Buddhas." In Schlagintweit's *Buddhism in Tibet*, is given the "Buddhas of Confession," a modern ritual containing a very long list of the saints to be invoked. As with Catholics each saint has his day. The Persians taught that the dead were confined in the tomb, awaiting a day of judgment, an idea taken over afterwards by the Christians. In spite of all this a long list of Fravashis, or ancestors, is invoked in the Favaridin Yasht of the Khordah Avesta. We know, too, how the Buddhist saint worship was taken over by the early church, which, however, a little illogically tried to work in the Persian Day of Judgment as well.

Islam preached that nothing was to be listened to except the words of Mahomet; but ancestor worship soon found its way in. The rites of the Moslem are almost confined now to offerings made at the tombs of the saintly. And oddly enough the Hindoos in India sometimes go and present their offerings likewise to the Mussulman Pirs.

Modern America suddenly discovered that it wanted a new creed. That it should make a jump to the religion of the Rig Veda, the religion of the early Dolmen, is significant. And this religion has already made gigantic strides. It is the religion of Thackeray, Dickens, Shelley, Blake, Bulwer Lytton, Dante Rossetti, Fichte. Victor Hugo wrote automatically, "Sardon has drawn in a

similar manner. Paris is honeycombed with Martinistes, Kabbalists, Occultists innumerable.

Theodore Parker, in 1856, wrote in his private journal as follows: "It seems now more likely that Spiritualism will become the religion of America than in 156 it did that Christianity would become the religion of the Roman Empire, or in 856 that Mohammedanism would be that of the Arabian population. 1. It has more evidence for its wonders than any historic form of religion hitherto. 2. It is throughout democratic, with no hierarchy, but inspiration open to all. 3. It does not claim to be a finality; it is not a *punctum stans*, but a *punctum flans*. 4. It admits all the truths of morality and religion in all the world's sects."

Mrs. Barrett Browning, in a letter to Dr. Marston quoted in the *Arena* (August, 1892), writes thus:—

"For theories, we get over no difficulty, it seems to me, by escaping from the obvious inference of an external spiritual agency. When the phenomena are attributed, for instance, to a 'second personality, projected unconsciously and attended by an unconscious exercise of volition and clairvoyance,' I see nothing clearly but a convulsive struggle on the part of the theorist to get out of a position he does not like, at whatever expense of kicks against the analogies of God's universe. When all is said, 'solve the solution,' we have a right to cry—And although, of course, sensible men in general would rather assert that two and three make four than that spirits have access to them, we, women and poets, cannot be expected to admit that two and three make four without certain difficulties and hesitations on our own side.

"Even with respect to the theory which occurs to yourself, you say that sometimes you cannot cleave to it as satisfactory, simply because we don't 'live deeper' when we go to Mrs. Hayden. Some of us have sat hour after hour in solitudes and silences God has made for us, listening to the inner life, questioning the depths and heights: yet the table did not tremble and tilt, and we had no 'involuntary answers' from the deep of the soul, in raps or mystical sighs, or bell-like sounds against the window. It will have occurred to you, too, on further consideration,

that the manifestations have not come, for the most part, through *deep lives*; and, again, that if they came through deeper modes of living, they would be profound in proportion to the profundity of the life; they would scarcely ever be frivolous and commonplace. You escape from no difficulty by your theory.

“To my mind, the only light which has been thrown on the manifestations comes from Swedenborg’s philosophy, *quoad*, the spiritual world as to state and relations. This philosophy explains much that is incomprehensible under other systems—as to the apparent ignorance and infidelity, for instance; the frivolity and stupidity of many of the spirits (so called); the perplexing quantity of personation; and the undeniable mixture of the pure and heavenly with all these.”

APPENDIX, No. II.

MADAME BLAVATSKY.

WHILST this is going to press, an article, cautiously worded, has appeared in *Light*, which seems to show that the accusations of dressing up fictitious Mahatmas, and of preparing sham miracles, are not confined to the writings of Madame Coulomb.

Mr. William Emmette Coleman has made some serious charges against the founders of the Theosophical Society in a paper read at the Chicago Congress. Mr. Coleman says that conclusive proofs of every assertion he makes are in his possession, and that they will be embodied in a work which he is now preparing for publication. There are several columns of accusation in the *Religio-Philosophical Journal*, and it will be for those whom it concerns to prove the falseness of Mr. Coleman's assertions. We feel bound to give one or two extracts from the paper read at Chicago, with no desire except that of eliciting the truth. It must always be remembered that Mr. Coleman promises proofs. Says Mr. Coleman:—

“Early in 1875 we find Colonel Olcott and Madame Blavatsky in Philadelphia, assuming to investigate the so-called Spiritualistic phenomena manifested in the presence of Mr. and Mrs. Nelson Holmes. Certain alleged materialisations of John and Katie King, through the Holmeses, had a short time before been denounced as fraudulent by Robert Dale Owen; and the confederate who had personated Katie King had made a confession of her guilt. Colonel Olcott published in 1875 a narrative of the investigations of himself and Madame Blavatsky, and they declared that the phenomena were all genuine, and that the *exposé* of the Holmeses was due to a con-

spiracy against them. That the whole of the manifestations through the Holmeses were fraudulent is beyond reasonable doubt. They have been many times caught in the act of trickery; and, being detected in such, not long after the publication of Olcott's narrative, Madame Blavatsky, having accomplished her purpose with them, namely, that of deluding Colonel Olcott into the belief of the possession of remarkable psychic power by her (Madame Blavatsky), publicly repudiated further connection with them.

“Madame Blavatsky had claimed to be herself a medium for the same ‘John King’ utilised by the Holmeses, and Olcott has told us of various psychic phenomena seen by him claiming to emanate from John King, and performed through Madame Blavatsky. It is evident that Madame Blavatsky and the Holmeses were in collusion in the production of spurious phenomena palmed off on Olcott as genuine. R. B. Westbrook, LL.D., one of the original officers of the Theosophical Society, stated in the *Religio-Philosophical Journal*, Chicago, September 14th, 1880, that Mrs. Holmes had admitted as much, and had stated that Madame Blavatsky proposed to her a partnership in the ‘materialisation show business,’ with Colonel Olcott as manager, claiming that she had already so ‘psychologised him that he did not know his head from his heels.’ Early in 1875 Madame Blavatsky sent to General F. J. Lippitt a picture, which she said had been painted for the General by the spirit John King himself. In *Mind and Matter*, Philadelphia, November 27th, 1880, was published conclusive evidence, found in Madame Blavatsky's room in Philadelphia, that she had herself painted this picture, except certain flowers, etc., which were already on the satin when she procured it. Madame Blavatsky is known to have had fair skill as a painter. Further, Mrs. Hannah M. Wolff, of Washington, D. C., in a published account of her experience with Madame Blavatsky in 1874, has stated that, Madame Blavatsky having claimed that certain pictures were painted by spiritual power direct, she was watched by three journalists residing in the same house, and they saw Madame Blavatsky get up in the night and paint them herself.”



“Another story is very extraordinary, and we trust its contradiction will be complete and conclusive. The doctor spoken of is Dr. Westbrook:—

“A woman, strangely attired and veiled, came into the doctor's house, during a meeting there at which Rev. W. R. Algar, Olcott, and H. P. Blavatsky were present, and handed the latter a letter purporting to come from the “Brothers”—the messenger being presumed to be an “elementary.” A few months afterwards Dr. Westbrook discovered that the presumed elementary was an Irish servant girl, to whom Madame Blavatsky had promised to pay five dollars for the personation of the messenger of the “Brothers.” Having failed to get her pay, she confessed the fraud.”

“We await with anxiety Mr. Coleman's promised book, and after that the defence of those he accuses.”

I may mention another point. In his *Incidents in the Life of Madame Blavatsky* (p. 69), Mr. Simmert announces that the Russian lady, “in an appropriate disguise,” was smuggled into Tibet from Cashmir by a solitary Shaman or Buddhist priest.

A paper was read before the Geographical Society on February 20th, 1893, by Captain Bower, describing a real trip that he made into Tibet from the same point as the Russian lady.

He started from Cashmir on the 14th April, and took six weeks to get to Leh, a distance of some 130 miles from Sri Nagar, as the crow flies. Between India and Tibet is the most formidable mountain wall in the world. It is everywhere from 70 to 120 miles thick, rock, and glacier, and precipice.

To Leh the tents, food, and baggage of the little caravan had to be carried by coolies through the Zoji La Pass. The baggage ponies without burdens had to be led by other natives, so steep were the paths. From Leh alone could they begin to carry their loads.

The trip from Cashmir to the vicinity of Lha Sa, where they were all turned back, and had to go off to China, occupied seven months. For five of these they never encamped below 15,000 feet elevation. The thermometer

registered minus 15° in summer. With the aid of a Chinese passport, patience, tact, English breech-loaders, and Indian rupees, they got round many officials, who all swore that they would themselves be decapitated unless they murdered their visitors.

All this allows us to judge whether a Russian lady, without tents, baggage, a store of food, without coolies, and without a passport, could have made her exceptionally long journey into the heart of Tibet, and reached the celebrated monastery where the Brahmins hide away their holy books, and only allow "refuse scraps," such as the Rig Veda and the Upanishads, to be seen in India. Starting in April, Captain Bower had the summer months before him. Starting in September, Madame Blavatsky must have traversed the ghats or passes in the *middle of winter*. These average 16,000 feet above the sea level, says Brian Hodgson in his *Geography of the Himalayas* (p. 10), and he adds that they are choked with snow for nine months of the year. And even if we concede that Madame Blavatsky got through them in safety, we still would require some additional information about the holy books which the Brahmins hide away in inaccessible places, in the hands of their most detested religious opponents. What would be said if the Archbishop of Canterbury placed the Christian Scriptures under the exclusive guardianship of the head Ulema at Constantinople, and ordered the Apocryphal Gospels and Epistles alone to be read in churches?







—

